



## Emergency Luminaire with LED

Series EXLUX L409/4



## Contents

1	General Information .....	3
1.1	Manufacturer .....	3
1.2	Information regarding the operating instructions .....	3
1.3	Further documents .....	3
1.4	Conformity with standards and regulations .....	3
2	Explanation of the symbols .....	4
2.1	Symbols in these operating instructions .....	4
2.2	Warning notes .....	4
2.3	Symbols on the device .....	5
3	Safety notes .....	5
3.1	Operating instructions storage .....	5
3.2	Safe use .....	5
3.3	Intended Use .....	6
3.4	Modifications and alterations .....	6
4	Function and device design .....	6
4.1	Function .....	6
4.2	Device design .....	7
5	Technical data .....	9
6	Engineering .....	13
6.1	Mains operation .....	13
6.2	Emergency light blocking .....	14
7	Transport and storage .....	16
7.1	General .....	16
7.2	Batteries .....	16
8	Mounting and installation .....	16
8.1	Dimensions / fastening dimensions .....	17
8.2	Removing protective foil .....	19
8.3	Mounting / dismantling, operating position .....	19
8.4	Installation .....	22
9	Commissioning .....	27
10	Operation .....	27
10.1	Operating Modes .....	27
10.2	Functional and rated operating time test .....	28
10.3	Indications .....	29
10.4	Troubleshooting .....	30
11	Maintenance, Overhaul, Repair .....	31
11.1	Maintenance .....	31
11.2	Repair .....	34
11.3	Returning the device .....	34
12	Cleaning .....	35
13	Disposal .....	35
14	Accessories and Spare parts .....	35

# 1 General Information

## 1.1 Manufacturer

R. STAHL Schaltgeräte GmbH  
Am Bahnhof 30  
74638 Waldenburg  
Germany

Phone: +49 7942 943-0  
Fax: +49 7942 943-4333  
Internet: r-stahl.com  
E-mail: info@r-stahl.com

R. STAHL (P) LTD., Plot No. - 5  
Malrosapuram Road, Sengundram Indl. Area  
Singaperumal Koil, Kancheepuram Dist.,  
Tamil Nadu – 603 204, INDIA

Phone: +91 44-67 300 600  
Fax: +91 44-67 300 700  
Internet: r-stahl.com/en/in  
E-mail: sales@rstahl.net

R. STAHL Schaltgeräte GmbH  
Business Unit Lighting & Signalling  
Nordstr. 10  
99427 Weimar  
Germany

Phone: +49 3643 4324  
Fax: +49 3643 4221-76  
Internet: r-stahl.com  
E-mail: info@r-stahl.com

## 1.2 Information regarding the operating instructions

ID-No.: 278238 / L40960300020  
Publication Code: 2022-10-06-BA00-III-en-02

The original instructions are the English edition.  
They are legally binding in all legal affairs.

## 1.3 Further documents

- Data sheet
- For documents in additional languages, see r-stahl.com.

## 1.4 Conformity with standards and regulations

IECEX, ATEX, EU Declaration of Conformity and further national certificates can be downloaded via the following link: <https://r-stahl.com/en/global/support/downloads/>.

## 2 Explanation of the symbols

### 2.1 Symbols in these operating instructions

Symbol	Meaning
	Tips and recommendations on the use of the device
	Danger due to energised parts



### 2.2 Warning notes

Warnings must be observed under all circumstances, in order to minimize the risk due to construction and operation. The warning notes have the following structure:

- Signalling word: DANGER, WARNING, CAUTION, NOTICE
- Type and source of danger/damage
- Consequences of danger
- Taking countermeasures to avoid the danger or damage

	<b>DANGER</b>
	Danger to persons Non-compliance with the instruction results in severe or fatal injuries to persons.
	<b>WARNING</b>
	Danger to persons Non-compliance with the instruction can result in severe or fatal injuries to persons.
	<b>CAUTION</b>
	Danger to persons Non-compliance with the instruction can result in light injuries to persons.
<b>NOTICE</b>	
Avoiding material damage Non-compliance with the instruction can result in material damage to the device and / or its environment.	

## 2.3 Symbols on the device

Symbol	Meaning
 <small>17055E00</small>	CE marking according to the current applicable directives.
 <small>23486E00</small>	UKCA marking according to the current applicable directives.

## 3 Safety notes

### 3.1 Operating instructions storage

- Read the operating instructions carefully.
- Store the operating instructions at the mounting location of the device.
- Observe applicable documents and operating instructions of the devices to be connected.

### 3.2 Safe use

#### Before mounting

- Read and observe the safety notes in these operating instructions!
- Ensure that the contents of these operating instructions are fully understood by the personnel in charge.
- Use the device in accordance with its intended and approved purpose only.
- Always consult R. STAHL Schaltgeräte GmbH if using the device under operating conditions which are not covered by the technical data.
- We cannot be held liable for damage to the device caused by incorrect or unauthorised use or non-compliance with these operating instructions.

#### For assembly and installation

- Observe national assembly and installation regulations.
- Observe national safety and accident prevention regulations.
- During installation and operation, observe the information (characteristic values and rated operating conditions) on the type plates and data plates and information signs located on the device.
- Before installation, make sure that the device is not damaged.

#### Maintenance, repair, commissioning

- Before commissioning, make sure that the device is not damaged.
- Work on the device, such as installation, maintenance, overhaul, repair, may only be carried out by appropriately authorised and trained personnel.
- Perform only maintenance work or repair described in these operating instructions.

### 3.3 Intended Use

The luminaire is equipment

- for lighting areas, work spaces and objects
- for emergency lighting in case of power failure.
- can be used indoors and outdoors
- for stationary mounting
- for use in the safe area.

### 3.4 Modifications and alterations

	No liability or warranty for damage resulting from modifications and alterations.
---	---

## 4 Function and device design

### 4.1 Function

#### Application range

The luminaire L409/4 is equipment used for lighting areas, work equipment and objects. It can be used indoors or outdoors and is suitable for emergency lighting in case of power failure.

#### Mode of operation

A weekly functional test and annual rated operating time test have been permanently integrated.

When opened using a central lock, the luminaire switches off automatically (optional).

The operating hours can be determined and the luminaire can be dimmed and switched via an optional DALI interface.

## 4.2 Device design

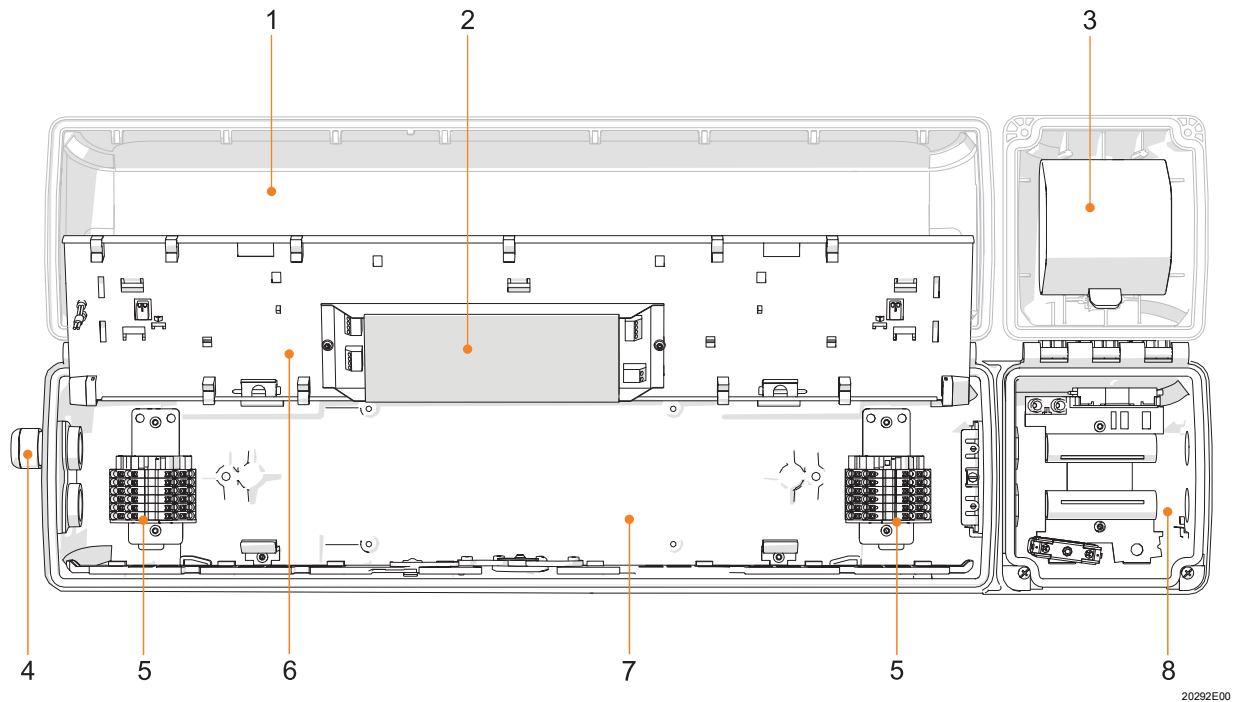

- |   |                   |   |                              |
|---|-------------------|---|------------------------------|
| 1 | Translucent cover | 5 | Connection terminal          |
| 2 | Control gear      | 6 | Mounting plate (bottom side) |
| 3 | Battery           | 7 | Luminaire enclosure          |
| 4 | Cable entry       | 8 | Battery enclosure            |

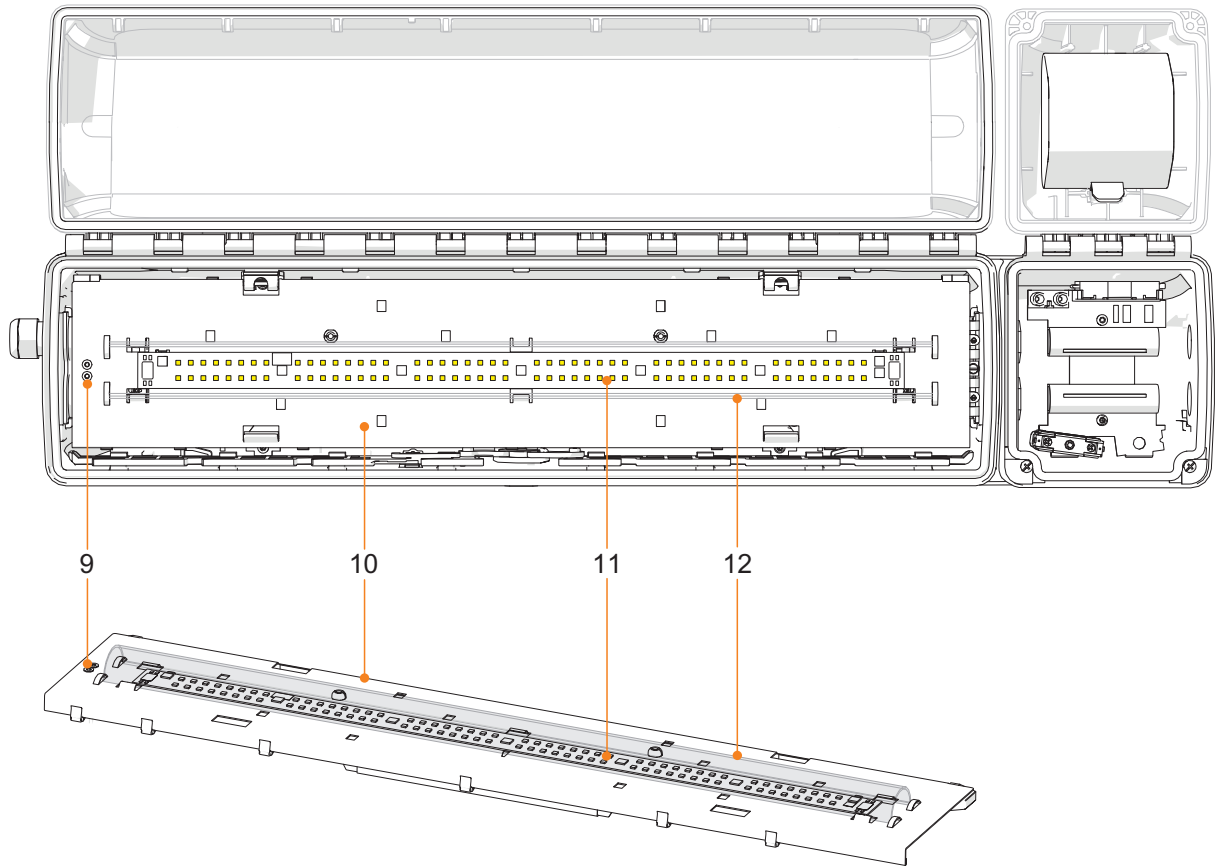

20293E00

- |    |                           |    |          |
|----|---------------------------|----|----------|
| 9  | LED indicator             | 11 | LED PCB  |
| 10 | Mounting plate (top side) | 12 | Diffuser |



## 5 Technical data

### Technical Data

#### Electrical data

Rated operational voltage	AC: 110 to 240 V $\pm 10$ %; 50 to 60 Hz				
Rated insulation voltage	250 V				
Rated operational current	<b>Size 2</b>		<b>Size 4</b>		
	At nominal voltage	110 V	230 V	110 V	230 V
	During stand-by switching mode	< 0.08 A	< 0.08 A	< 0.08 A	< 0.08 A
Inrush current	In continuous mode	0.24 A	0.13 A	0.43 A	0.21 A
	$I_{\text{peak}} = 62 \text{ A}$ ; $\Delta t = 122 \mu\text{s}$ maximum number of luminaires per miniature circuit breaker at 230 V:				
	<b>Type</b>	<b>10 A</b>	<b>16 A</b>	<b>20 A</b>	<b>25 A</b>
	<b>B</b>	10	17	21	27
	<b>C</b>	18	28	36	45
	<b>K</b>	36	57	72	90
Power factor	<b>Size 2</b>		<b>Size 4</b>		
	At nominal voltage	110 V	230 V	110 V	230 V
		$\geq 0.98$	$\geq 0.90$	$\geq 0.99$	$\geq 0.95$
THD	Size 2: < 15 % Size 4: < 8 %				
Protection class	I (with internal PE connection)				

#### Luminous characteristics

Colour rendering	$R_a \geq 80$				
Colour temperature	Depending on the variant, 2,700 K (warm white), 4,000 K (warm neutral white), 5,000 K (standard light colour, neutral white) or 6,500 K (daylight white)				
Luminous flux	<b>Size 2</b>		<b>Size 4</b>		
	Power consumption [W]	25		45	
	Diffuser	with	without	with	without
	Luminous flux [lm]	2,910	3,230	5,810	6,460
	Luminaire efficacy [lm/W]	116	129	129	144

Values apply to  $T_a = +25 \text{ }^\circ\text{C}$ .

Energy efficiency class of the light source  
 The device contains a light source in energy efficiency class D (according to the Energy Labelling Regulation for light sources)

Technical Data

Luminous flux decline

at ambient temperature

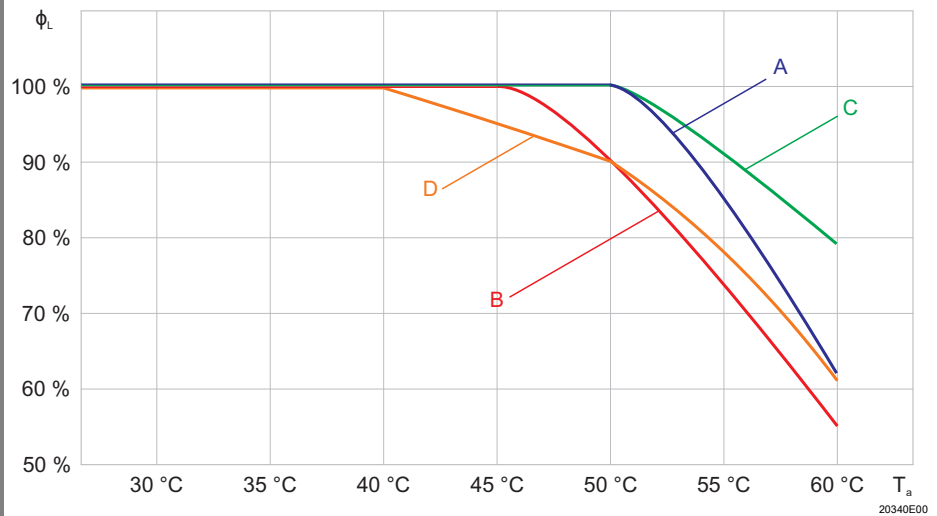

- A: Size 2; 230 V 50 Hz
- B: Size 4; 230 V 50 Hz
- C: Size 2; 110 V AC 60 Hz
- D: Size 4; 110 V AC 60 Hz

Ambient conditions

Ambient temperature

without through wiring	-30 to +60 °C (1, 2)
$I_N$ through wiring $\leq 10$ A	-30 to +55 °C (1, 2)
$I_N$ through wiring $\leq 16$ A	-30 to +50 °C (1)

(1) **Rated operating time during emergency light operation**  
is guaranteed within an ambient temperature range of -5 to +50 °C. This also applies to charging and discharging of the battery. The rated operating time might be reduced if used outside this temperature range.

(2) **Battery service life**  
is guaranteed within an ambient temperature range of -30 to +50 °C according to IEC/EN 60598-2-22.

Storage temperature -30 to +60 °C

Service life

LED Life Time

$L_{90B_{50}}$ : 100,000 h

$L_xB_y$

At the end of the service life:

- Luminous flux decline to "x" percent
- Up to "y" percent of all luminaires fall below "x"

LED control gear

$C_{10}$  at 60 °C  $\geq 100,000$  h  
 $C_{10}$  = failure rate 10 %

**Technical Data**

**Mechanical data**

Degree of protection	IP66 / IP67 (IEC 60598) IP64 if a breather is used
Impact strength (IK code)	IK10 (IEC 62262)
Material	
Enclosure	polyester resin, glass fibre reinforced
Enclosure colours	Grey colour, similar to RAL 7035
Lamp cover	Polycarbonate
Seal	Silicone seal, foamed into the translucent cover
Luminaire locking	Central lock for M8 / A/F 13 box spanner; the translucent cover can be swivelled on its hinge

**Mounting / Installation**

Cable glands	<p><b>Standard luminaire</b></p> <p>Plastic: 2 x M25 x 1.5 cable entries 8161 and 2 x M25 x 1.5 stopping plugs 8290 (enclosed)</p> <p>Metal: 2 x metal plates M20 x 1.5 connected by means of PE for metal cable entries Attention: cable entries must be ordered separately</p> <p>Special version: max. 4 drilled holes for M20, M25, NPSM ½" max. 2 drilled holes for NPT ¾"</p> <p>Metal cable glands: M20 x 1.5, M25 x 1.5; earthing metal cable entries using metal plates</p>
Connection	<p>Spring clamp terminals</p> <p>Standard: 6-pole: L1, L2, L3, L', N, PE with DALI: 8-pole: L1, L2, L3, L', N, PE, D1, D2</p> <p>Clamping range: 1 x 1.5 to 6 mm<sup>2</sup> (solid) 1 x 1.5 to 4 mm<sup>2</sup> (finely stranded) 1 x 1.5 to 6 mm<sup>2</sup> (finely stranded with core end sleeves) (2 free clamping units per pole available)</p>
Through wiring	<p><b>Standard luminaire with</b></p> <p>Luminaires are equipped with internal through wiring. Connection of ingoing and outgoing leads on opposite sites is possible. Terminals: See Tech. data Wiring cross section of the supply line connection: 2.5 mm<sup>2</sup> for max. 16 A (Observe service temperature)</p> <p><b>Optional without</b></p> <p>On the connection side, there are 2 bores M25 x 1.5 for cable entries for through wiring of the connection line (ingoing and outgoing leads on one side).</p>

**Technical Data**

<p>Assembly</p>	<p><b>Standard luminaire</b></p> <p>Standard: 2 x M8 insert nuts in the enclosure</p> <p>Special: Mounting grooves in the enclosure for use of fastening and ceiling rails for variable luminaire mounting (variable mounting distances for luminaires L = 700 mm: 320 to 480 mm; L = 1310 mm: 670 to 930 mm)</p>															
<p><b>Control gear</b></p> <p>Emergency light mode</p> <p>Rated operating time</p>	<p>In case of power failure the LEDs are supplied by the battery</p> <p>at optimal ambient temperature of the battery:</p> <table border="1" style="width: 100%; border-collapse: collapse;"> <thead> <tr> <th rowspan="2">Battery capacity</th> <th rowspan="2">Rated operating time</th> <th colspan="2">Emergency light output</th> </tr> <tr> <th>Size 2</th> <th>Size 4</th> </tr> </thead> <tbody> <tr> <td rowspan="2">7 Ah</td> <td>1.5 h</td> <td>65 %</td> <td>35 %</td> </tr> <tr> <td>3.0 h</td> <td>35 %</td> <td>20 %</td> </tr> </tbody> </table>			Battery capacity	Rated operating time	Emergency light output		Size 2	Size 4	7 Ah	1.5 h	65 %	35 %	3.0 h	35 %	20 %
Battery capacity	Rated operating time	Emergency light output														
		Size 2	Size 4													
7 Ah	1.5 h	65 %	35 %													
	3.0 h	35 %	20 %													
<p>Switchover voltage</p>	<p>From mains to battery operation at <math>U &lt; 0.83 \times U_N</math> From battery to mains operation at <math>U &gt; 0.88 \times U_N</math></p>															
<p><b>Battery set</b></p> <p>Version</p> <p>Operating voltage</p> <p>Capacity</p> <p>Replacing the battery set</p>	<p>NiCd battery, gas-tight</p> <p>6 V</p> <p>7 Ah</p> <p>When opening the battery enclosure, the connection between the battery and the control gear is disconnected by means of a switch. The battery set can be replaced after disconnecting the plug-in contacts.</p>															
<p><b>Optional</b></p> <p>DALI-connection</p> <p>Breather</p>	<p>DALI interface in accordance with IEC 62386-207:2009-08</p> <p>Breather 8162/1 from R.STAHL Schaltgeräte GmbH The breather guarantees compliance with degree of protection IP64 in all mounting positions. The breather may not be used in atmospheres with corrosive gasses.</p>															

For further technical data, see [r-stahl.com](http://r-stahl.com).

## 6 Engineering

### 6.1 Mains operation

#### 6.1.1 Stand-by operation

- The light fitting is switched off.

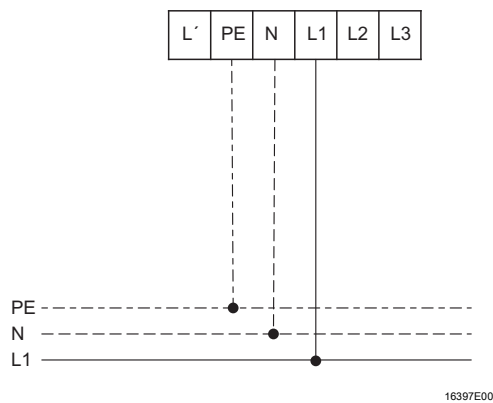

#### 6.1.2 Continuous operation

- The light fitting is switched on.

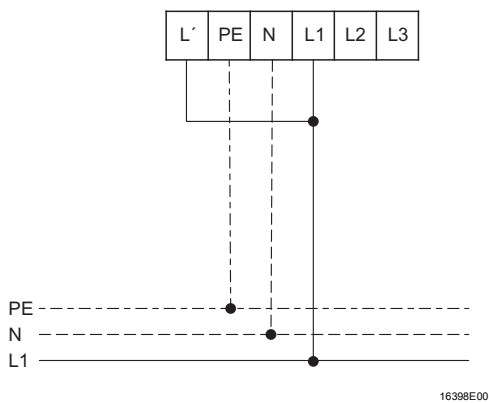

#### 6.1.3 Normal lighting operation

- The light fitting is operated by normal lighting.

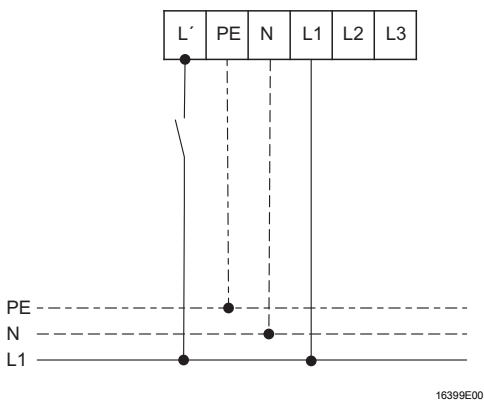

## 6.2 Emergency light blocking

A remote switch for emergency light blocking can be connected to terminals "Remote-switch" of the control gear.

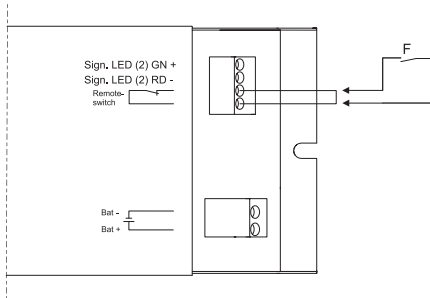

19192E00

	<b>Remote switch is closed</b>	<b>Remote switch is opened</b>
Power supply operation	Switching on the luminaire depending on operation mode	Switching on the luminaire depending on operation mode
Power failure	Emergency light function	No emergency light function

### 6.2.1 Connection version remote switch

The remote switch is directly connected to the control gear.

The following connection versions are possible:

#### Point-to-point connection

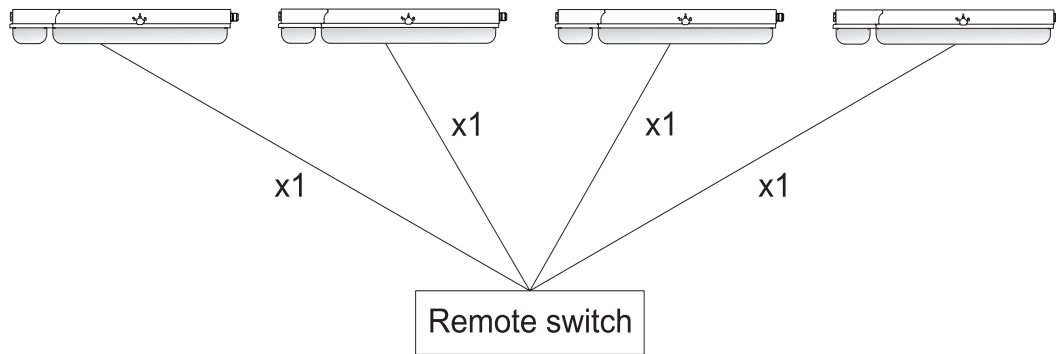

18474E00

## Linear connection

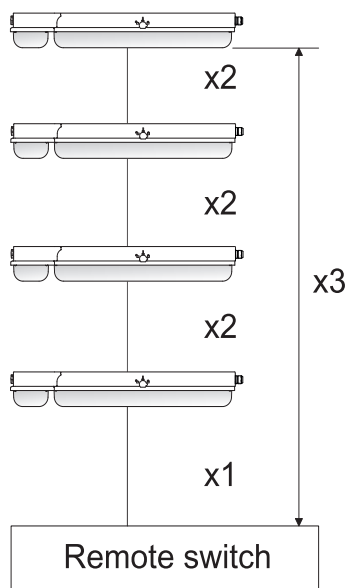

18473E00

The following conductor specifications must be observed during connection.

	Point-to-point connection	Linear connection
maximum conductor length		
x 1	500 m	100 m
x 2		50 m
x 3		500 m
maximum number of light fittings	50	30
Cable cross section	1.5 mm <sup>2</sup>	1.5 mm <sup>2</sup>

## 7 Transport and storage

### 7.1 General

- Transport and store the device only in the original packaging.
- Store the device in a dry place (no condensation) and vibration-free.
- Do not drop the device.

### 7.2 Batteries

- Do not transport together with other materials.
- Do not transport in explosive dust atmosphere.
- Handle with care.
- Store protected from fire, sources of dust, harmful gases and liquids.
- Store in a dry and cool location.

#### **NOTICE**

Risk of deep battery discharge due to exceeded storage!

Non-compliance can result in material damage!

- The battery should be charged within 26 weeks from date of production by means of operating the luminaire.

#### **Recommendation:**

- Store battery at an ambient temperature of +5 to +25 °C and a relative humidity of 65 ±5 %. The storage period is reduced of up to one month if stored outside this temperature range.

## 8 Mounting and installation

#### **NOTICE**

Malfunction or device damage caused by condensation.

Non-compliance can result in material damage!

- operate the luminaire continuously or periodically over extended periods of time.
- Avoid thermal bridges, use suitable installation accessories.



### 8.1 Dimensions / fastening dimensions

Dimensional drawings (all dimensions in mm [inches]) – Subject to modification

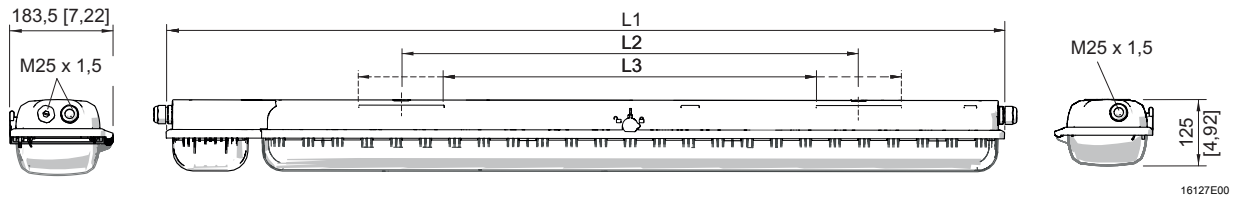

Dimensions	Luminaire	
	Size 2	Size 4
L1	857 [33.74]	1467 [57.76]
L2 <sup>1)</sup>	400 [15.75]	800 [31.50]
L3 <sup>2)</sup>	320 to 480 [12.60 to 18.90]	670 to 930 [26.38 to 36.61]

<sup>1)</sup> fixed mounting distance

<sup>2)</sup> variable mounting distance

### EXLUX L409/4

Dimensional drawings for assembly parts and accessories (all dimensions in mm [inches]) – Subject to alterations

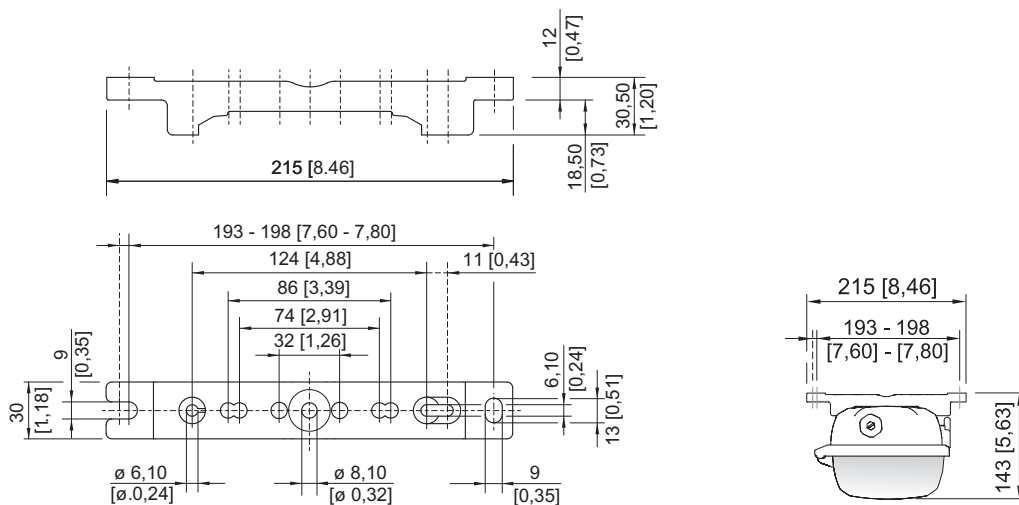

### Mounting rail

**Dimensional drawings for assembly parts and accessories**  
(all dimensions in mm [inches]) – Subject to alterations

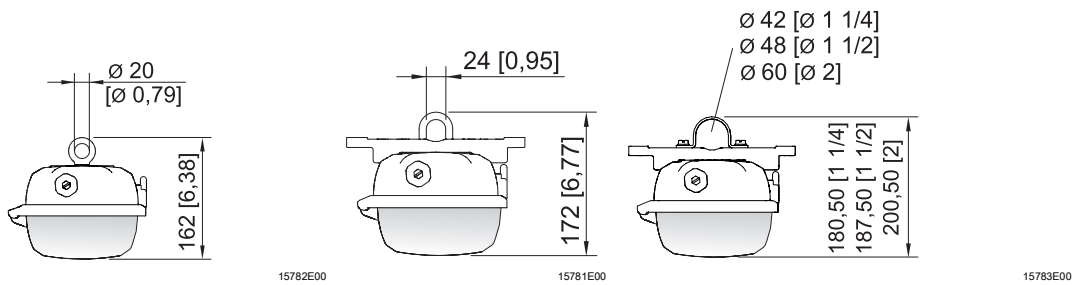

**Ring bolt fitted in insert nut of the luminaire**

**Mounting bracket fitted in mounting rail**

**Pipe clamp fitted in mounting rail**

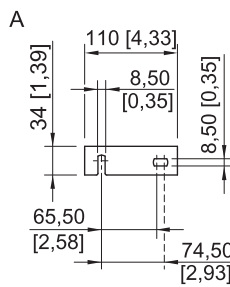
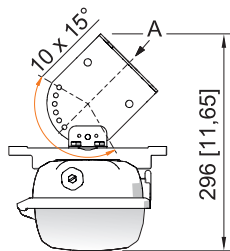

**Wall mounting bracket fitted in mounting rail**

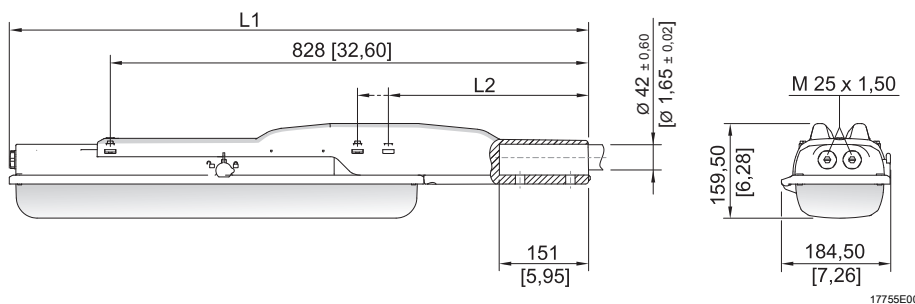

Dimensions	Luminaire	
	Size 2	Size 4
L1	1135 [44.69]	1744 [68.66]
L2	390 [15.35]	338 [13.31]

**Linear luminaire EXLUX with pole mounting sleeve**

## 8.2 Removing protective foil

As standard, the luminaire is generally delivered with protective foil on the translucent cover. However, in some cases, it can be delivered without protective foil.

- If protective foil is available:  
Remove protective foil prior to commissioning.

## 8.3 Mounting / dismounting, operating position

<b>i</b>	<p>The luminaire is suitable for wall and ceiling mounting. In event of wall mounting in outdoor areas, avoid installation with central lock at top. The mounting position with upward light emission in outdoor areas is prohibited.</p>
----------	---

### Suspension at fixed mounting points

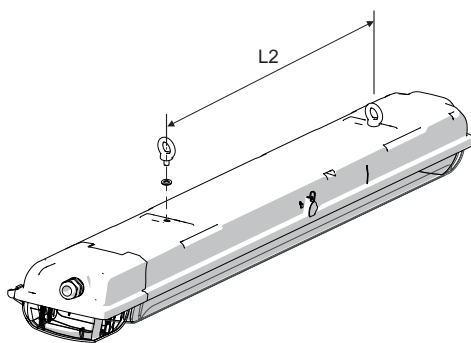

Size	L2 mm [inch]
2	400 [15.75]
4	800 [31.50]

max. screw-in depth 10 mm [0.39]

16324E00

### Suspension at movable mounting parts

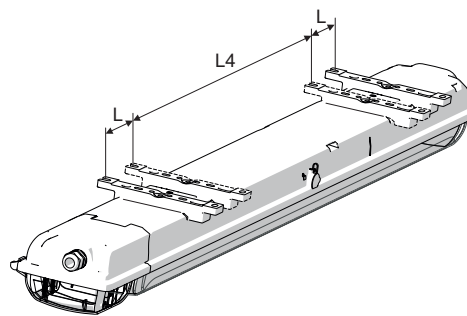
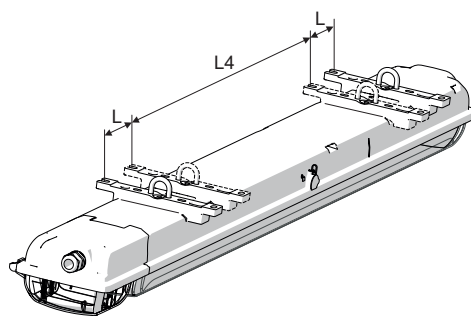

16325E00

16326E00

#### Mounting bracket

Size	L4 mm [inch]	L mm [inch]
2	320 [12.60]	80 [3.15]
4	670 [26.38]	130 [5.12]

#### Top rail

Lateral mounting pockets for variable points of suspension.

**i** When mounting the luminaire using top rails, ensure that the mounting surface is flat. Otherwise, the enclosure might be mounted in a warped/twisted way. The result is leakage of the luminaire and difficulties in replacing the translucent cover.

## Pole mounting using pole mounting sleeve

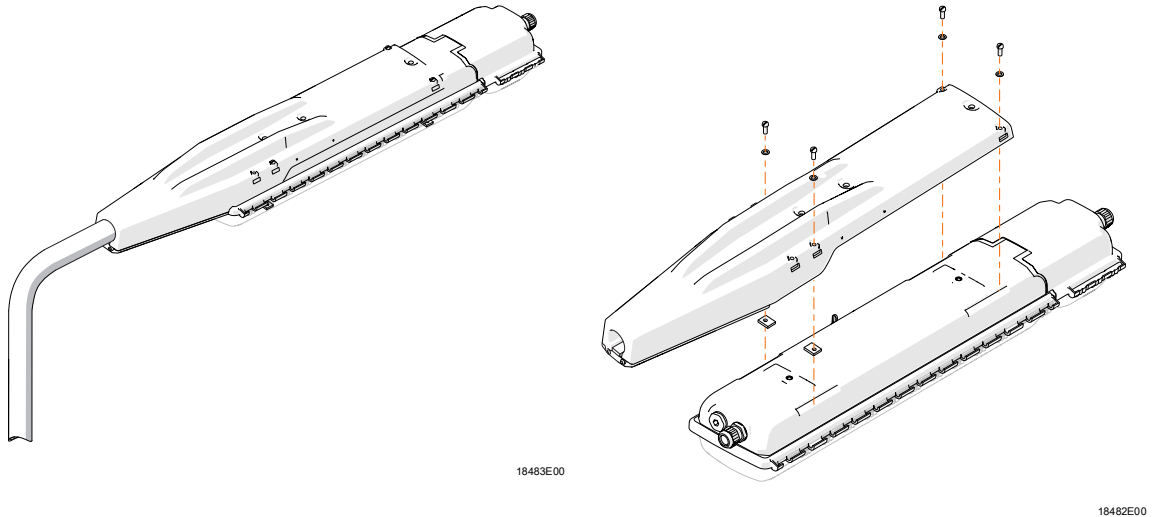

## Pole suspension Pole mounting using pipe clamps

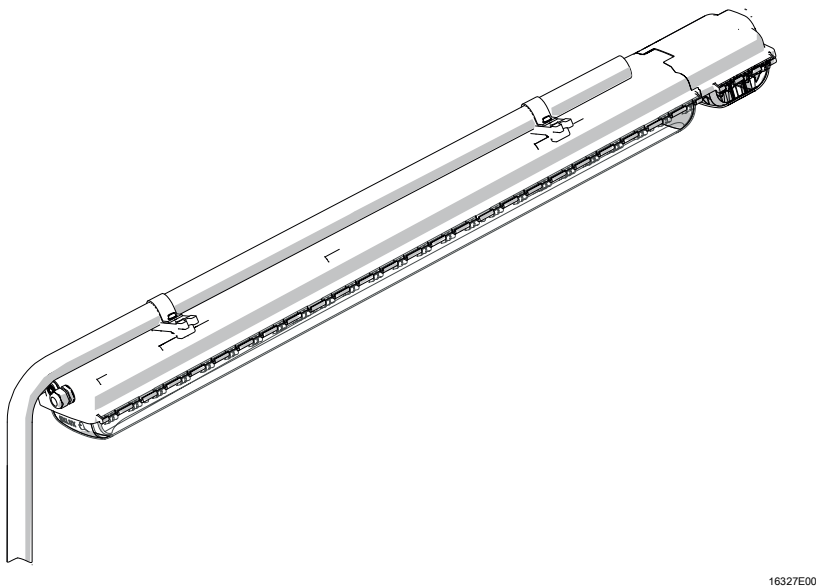

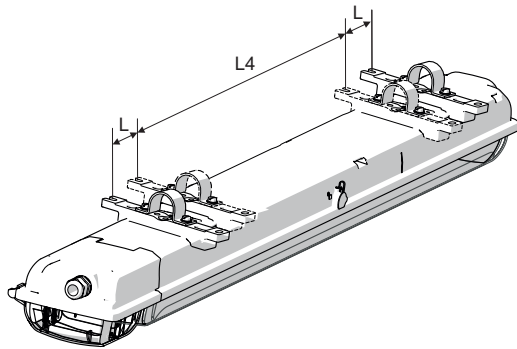

16328E00

Size	L4 mm [inch]	L mm [inch]
2	320 [12.60]	80 [3.15]
4	670 [26.38]	130 [5.12]

**i** For pipe clamp mounting, use the solution of R. STAHL Schaltgeräte GmbH with integrated mounting rail providing reliable and stable four-point fixing! In case of point suspension using pipe clamps, R. STAHL Schaltgeräte GmbH does not guarantee the strength and tightness of the luminaire!

**Wall bracket mounting**

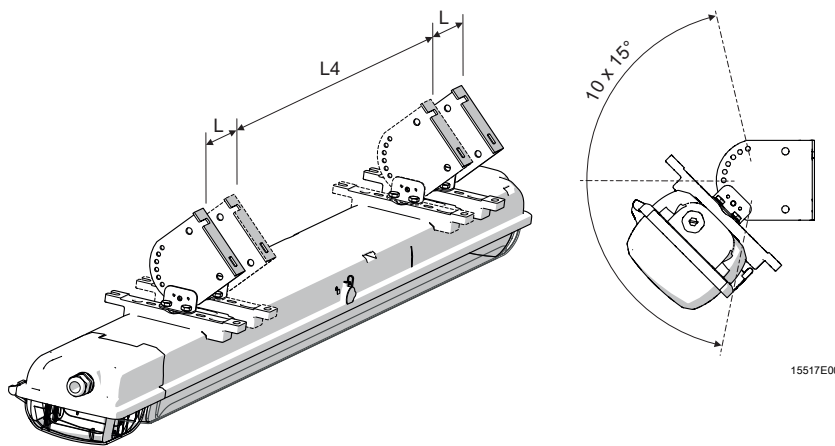



15515E00

Size	L4 mm [inch]	L mm [inch]
2	320 [12.60]	80 [3.15]
4	670 [26.38]	130 [5.12]

## 8.4 Installation

### 8.4.1 Opening and Closing of the Enclosure

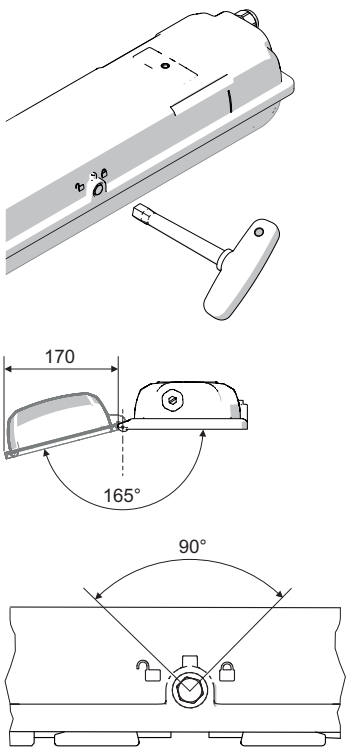
	<p style="text-align: center;"><b>DANGER</b></p> <p>Risk of electric shock due to improper opening! Non-compliance results in severe or fatal injuries.</p> <ul style="list-style-type: none"> <li>• Open luminaires without switch only in de-energized state (see information plate on the lock)!</li> </ul>
	<p><b>Recommendation</b></p> <p>Opening and closing of the luminaire by using a socket wrench from R. STAHL Schaltgeräte GmbH.</p>
 <p style="text-align: right; font-size: small;">15448E00 15451E00 15436E00</p>	<ul style="list-style-type: none"> <li>• Remove the closing cap of the central lock.</li> <li>• Turn the central lock using a box spanner M8, spanner size 13, by 90° to the left as far as it will go.</li> <li>• Swivel down the translucent cover.</li> <li>• Proceed in reverse order to close.</li> <li>• The seal of the translucent cover must lie correctly on the sealing edge.</li> <li>• Push the closing cap onto the central lock opening (protection against dirt).</li> </ul>



Observe the following during mounting and dismounting:

- Version without switch: Disconnect the luminaire from the power supply, secure it against being switched on again and open the battery case in order to disconnect from the battery voltage.
- Do not use force when opening or closing the enclosure.

Central lock

- Version with switch: The luminaire is positively disconnected from the power supply by actuating the central lock.
- In open end position and with translucent cover swivelled down, an anti-pumping device prevents the central lock from being actuated.

### Opening and closing the reflector plate

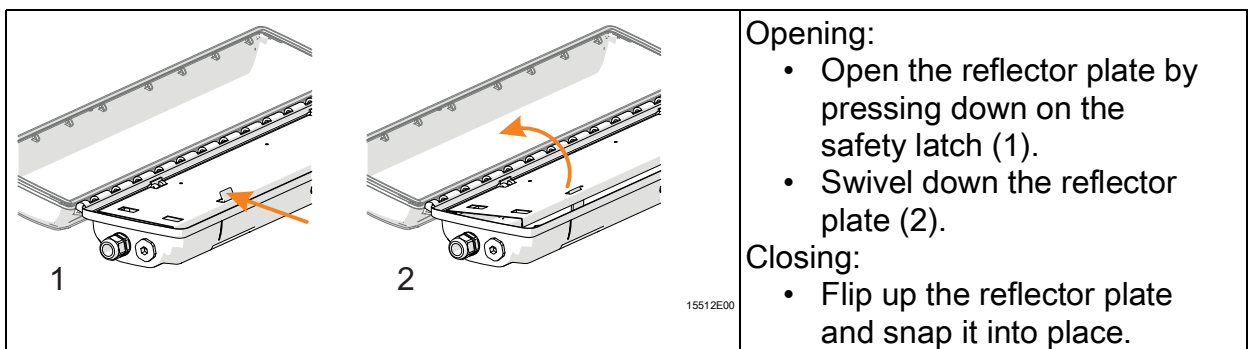

Opening:

- Open the reflector plate by pressing down on the safety latch (1).
- Swivel down the reflector plate (2).

Closing:

- Flip up the reflector plate and snap it into place.

### Opening and closing the battery case

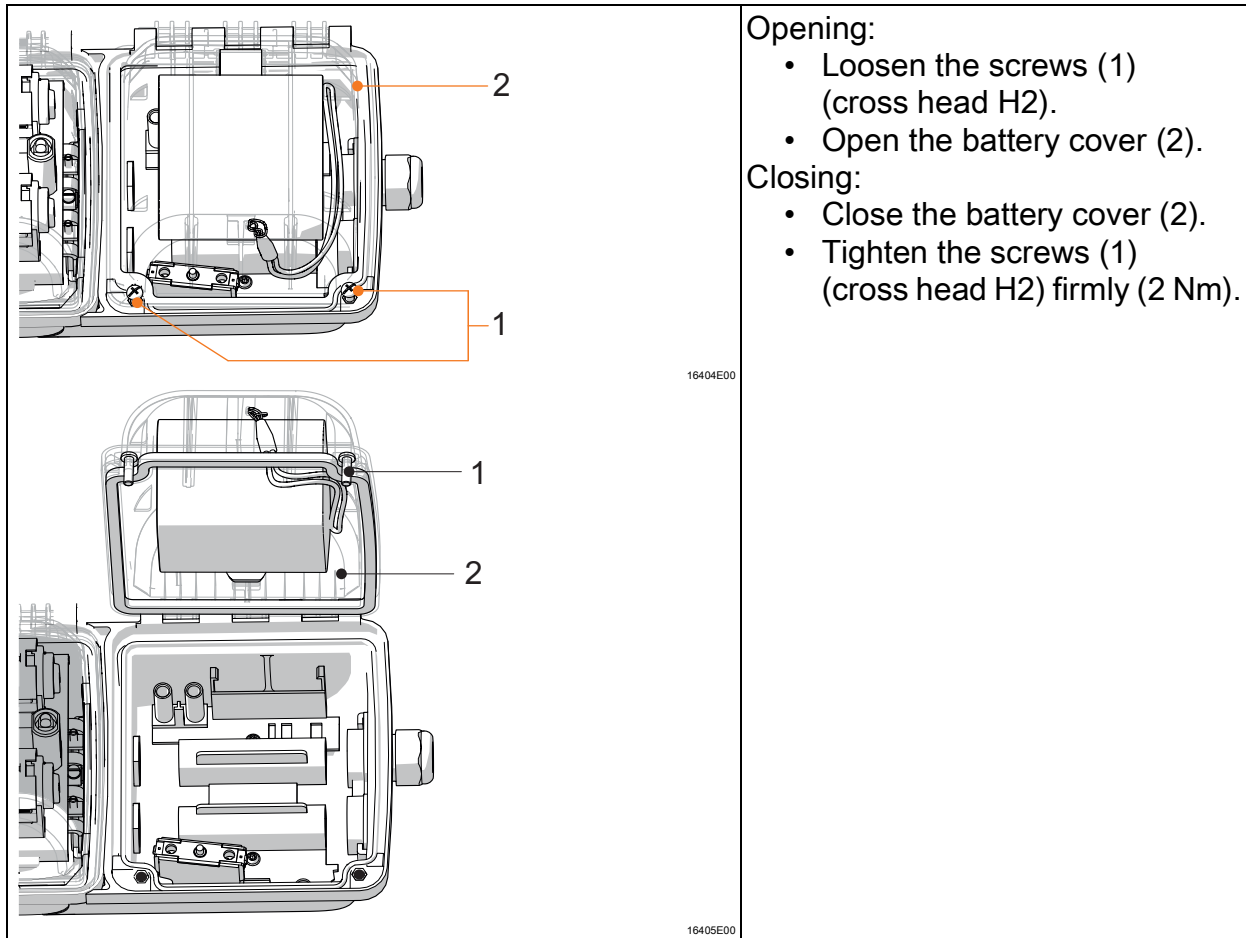

#### Opening:

- Loosen the screws (1) (cross head H2).
- Open the battery cover (2).

#### Closing:

- Close the battery cover (2).
- Tighten the screws (1) (cross head H2) firmly (2 Nm).

## 8.4.2 Electrical connections

### Electrical connection

Observe the maximum clamping possibility of the connecting terminals (see chapter "Technical data").

For optional screw terminals, two conductors per clamping unit can be clamped (through wiring).

Observe the following when connecting to the main supply:

- Clamping must be carried out precisely!
- Do not clamp any part of the conductor insulation!
- Do not mix up the conductors!
- Observe the technical regulations when connecting the conductor!
- Clamp the conductor firmly.
- Do not remove the terminal cover of optional screw terminals to clamp the conductor!
- The phase L1 must be directly connected to the grid which functions as charging phase for the battery!

### NOTICE

Danger due to wrong connection.

Malfunction

- Phases L and L1 must be connected in phase.



- Optional screw terminals: Firmly tighten screws (tightening torque 2 Nm, for unused clamping units 0.7 Nm)!

### Connection terminals

#### Clamping range:

- 1 x 1.5 to 6 mm<sup>2</sup> (solid)
- 1 x 1.5 to 4 mm<sup>2</sup> (finely stranded)
- 1 x 1.5 to 6 mm<sup>2</sup> (finely stranded with core end sleeves)
- (2 free clamping units per pole available)

#### Stripping length:

10 to 12 mm

#### Standard:

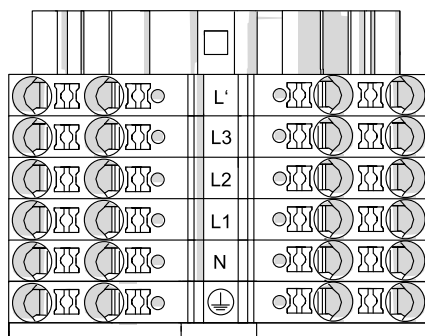

- L' = switched phase
- L1 = charging phase
- L2, L3 = phase
- N = neutral conductor
- ⊕ = protective conductor

20294E00

#### with DALI connection:

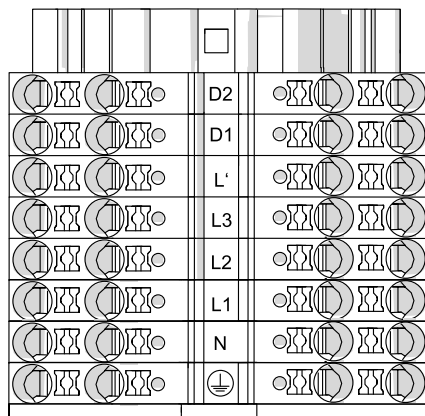

- D1, D2 = DALI connection
- L' = switched phase
- L1 = charging phase
- L2, L3 = phase
- N = neutral conductor
- ⊕ = protective conductor

20302E00

### Through wiring of the mains supply connection

<b>i</b>	Through wiring with 2.5 mm <sup>2</sup> cross section for max. 16 A.
----------	--

### Connection of remote switch to control gear

Connecting the remote switch to the potential-free contact "Remote switch" of the control gear.

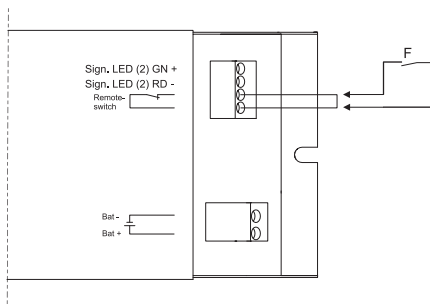

**Clamping range:**  
1.5 mm<sup>2</sup> solid, finely and  
extra finely stranded  
**Stripping length:**  
8.5 to 9.5 mm

19192E00

### 8.4.3 Cable entries

The standard luminaire is delivered with 3 lead-in holes, 2 cable glands and 2 stopping plug.

#### Tightening torques for components from R. STAHL Schaltgeräte GmbH

Luminaires with installed cable entries and stopping plugs from R. STAHL Schaltgeräte GmbH must be tightened using the following values:

		Tightening torque	
		Connection thread	Pressure screw
Cable entry 8161	M20 x 1.5	2.3 Nm	1.5 Nm
	M25 x 1.5	3.0 Nm	2.0 Nm
Stopping plugs 8290	M20 x 1.5	1.0 Nm	–
	M25 x 1.5	1.5 Nm	–

#### Luminaires with cable entries and stopping plugs which are not supplied by R. STAHL Schaltgeräte GmbH

Please observe the following:

- the required dust resistance!
- the required type of protection!
- the required temperature resistance!
- the IP degree of protection according to the rating plate!
- the operating instructions of the cable entries and stopping plugs!
- the required tightening torques!
- the range of the permissible cable diameter!
- Insert the metal cable entries and/or stopping plugs into the PE!

## 9 Commissioning

### NOTICE

Malfunction or device damage caused by condensation.

Non-compliance can result in material damage!

- operate the luminaire continuously or periodically over extended periods of time.
- Avoid thermal bridges, use suitable installation accessories.

Before commissioning, ensure the following:

- Check the mounting and installation.
- Check the device for damage.
- If necessary, remove foreign bodies.
- If necessary, clean the connection chamber.
- Check if the conductors have been inserted correctly.
- Check if all screws and nuts have been tightened firmly.
- Check if all drilled holes are closed.
- Check whether all the cable entries and stopping plugs have been tightened firmly.
- Check if all conductors have been clamped firmly.
- Check if the line voltage and the rated operational voltage are consistent.
- Check if the permissible conductor diameter for the corresponding cable entries have been used.
- Check if the device is closed according to regulations.
- Check if the battery is connected.
- the LED assembly and the diffuser are clean.
- Check that there is no protective foil on the translucent cover.

## 10 Operation

### 10.1 Operating Modes

Power supply operation:

Stand-by operation	The luminaire is switched off regardless of normal lighting.
Continuous operation	The luminaire is switched on regardless of normal lighting.
Normal lighting operation	The light fitting is operated by normal lighting.

**Emergency light operation:**

In the event of a power failure, the luminaire switches to emergency light operation. The luminaire is switched on regardless of the operation mode of the selected rated operating time.

**Rated operating time**

is 1.5 h or 3.0 h within the optimum temperature range depending on the variant (see chapter "Technical data").

**Emergency light blocking**

A remote switch for emergency light blocking can be connected to terminals "Remote-switch" of the control gear.

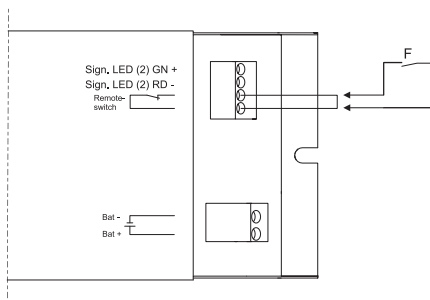

19192E00

	<b>Remote switch is closed</b>	<b>Remote switch is opened</b>
Power supply operation	Switching on the luminaire depending on operation mode	Switching on the luminaire depending on operation mode
Power failure	Emergency light function	No emergency light function

**10.2 Functional and rated operating time test**

To carry out the test, the following prerequisites must be fulfilled:

- the time interval has expired.
- the power supply operation was active for at least 1 hour.
- the remote switch is closed.

The test result is shown on the LED indicator. During a test the luminaire is switched on.

**Function test**

- starts within 24 hours after commissioning.
- is carried out every 7 days.
- takes 1 minute.
- checks the function of the LEDs and the battery.

**Rated operating time test**

- starts within 44 days after commissioning.
- is carried out once a year.
- checks the function and the operating time of the luminaire during emergency light mode.
- is repeated after 14 days if rated operating time test is faulty.

### 10.3 Indications

#### When connecting to the power supply

Initialisation within 10 seconds

Second	Description	
0 to 2	Function test green LED	
2 to 4	Function test red LED	
4 to 10	Status rated operating time test	Green LED flashes - rated operating time test active Green LED off - rated operating time test not active

Then the LED indicator switches to operating mode.

#### During power supply operation

Blinking: 1 second on, 1 second off

Flashing: 0.25 seconds on, 0.75 seconds off

Green	Luminaire is ready for operation	
Blinking green	Luminaire is ready for operation	Function and rated operating time test activated
Red	Error	Battery is defective or electric circuit is interrupted
Blinking red	Error	Last function and/or rated operating time test faulty
Flashing red	Error	LEDs defective
Blinking green/red	Luminaire is ready for operation, no emergency light operation	Emergency light operation is deactivated by remote switch
Flashing green/red	Luminaire is ready for operation	Reset signal detected

#### During emergency light operation

The LED indicator is switched off.

## 10.4 Troubleshooting

Refer to the following troubleshooting chart during troubleshooting:

<b>Cause of error</b>	<b>Troubleshooting</b>
The LEDs are defective.	Replace the mounting plate including LEDs and the control gear.
The control gear is defective.	Replace the mounting plate including LEDs and the control gear.
The switch is defective.	Replace the switch.

### **Red LED indicator**

The battery is defective.	Replace the battery.
The switch in the battery box is defective.	Replace the switch.
The switch in the luminaire is defective.	Replace the switch.

### **LED indicator blinking red**

The battery capacity is too low.	Replace the battery.
The LEDs are defective.	Replace the mounting plate including LEDs and the control gear.

The LED indicator lights up in green after troubleshooting.

If the error cannot be eliminated using the mentioned procedures:

- Contact R. STAHL Schaltgeräte GmbH.

For fast processing, have the following information ready:

- Type and serial number of the device
- Purchase information
- Error description
- Intended use (in particular input / output wiring)

## 11 Maintenance, Overhaul, Repair

	<b>CAUTION</b>
	<p>Risk of electric shock or malfunction of the device due to unauthorized work! Non-compliance can result in light injuries!</p> <ul style="list-style-type: none"> <li>• Before carrying out work on the device, switch off voltage supply.</li> <li>• Work performed on the device must only be carried out by authorized and appropriately trained qualified electricians.</li> </ul>

### 11.1 Maintenance

- Consult the relevant national regulations to determine the type and extent of inspections.
- Adapt inspection intervals to the operating conditions.

	Observe the relevant national regulations in the country of use.
---	--

During maintenance/overhaul of the device, the following points must be checked:

- Whether the clamping screws holding the cables are securely seated
- Whether the device has cracks or other visible signs of damage
- Whether the seal shows signs of ageing or damage (completely replace enclosure components with damaged foamed seal)
- Whether the device is clean inside and out
- Whether the cable entry is intact and securely tightened
- Whether the cables and lines show signs of ageing and damage
- Intended use and function.

#### 11.1.1 Replacing the luminaire cover

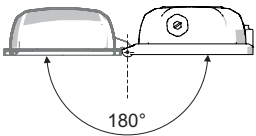
	<ul style="list-style-type: none"> <li>• Open the luminaire.</li> <li>• Swivel the translucent cover backwards by 180°.</li> <li>• Lift the translucent cover to detach it from the hinge.</li> <li>• Insert new translucent cover into the hinge.</li> <li>• All hinges must engage correctly.</li> <li>• Close the luminaire.</li> <li>• Observe safety notes!</li> </ul>
---	---

### 11.1.2 Battery replacement

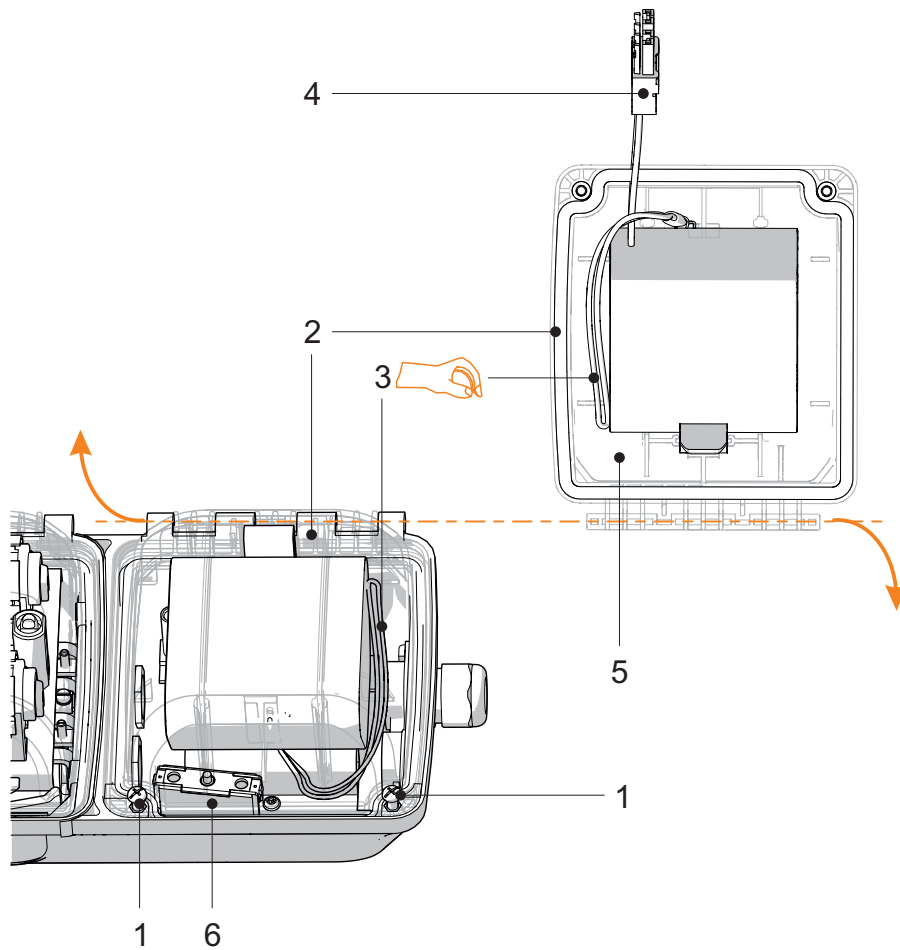

16387E00

1	Screws	4	Battery plug
2	Battery cover	5	Battery
3	Strap	6	Switch

- Loosen the screws (1) (cross head H2) in the battery cover (2).
- Open the battery case.
- The switch (6) disconnects the battery circuit.
- Secure the battery cover with installed battery to your wrist using the strap (3).



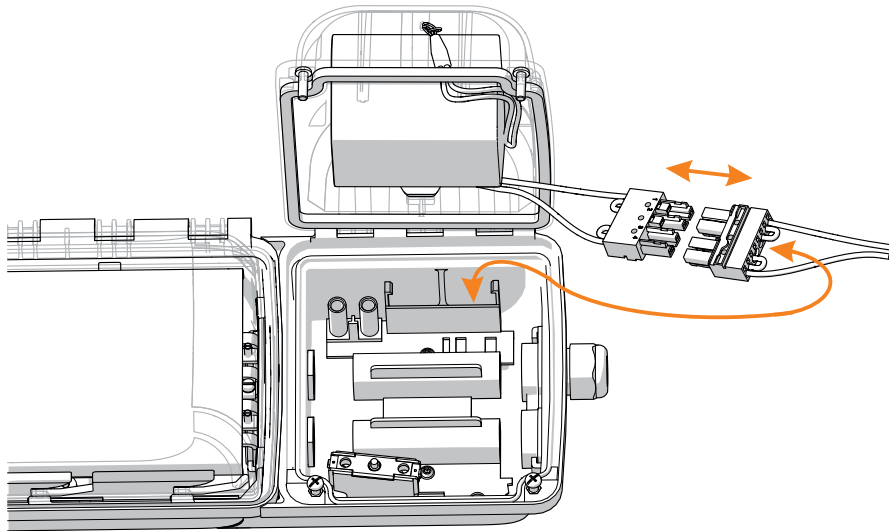

16406E00

- Remove the battery plug from the chamber.
- Disconnect the battery plug (4).
- Take off the battery cover with installed battery (5).
- Put on and secure the battery cover with installed battery (5).
- Connect the battery plug (4).
- Loosen the strap (3) from the wrist and store it in the battery case.

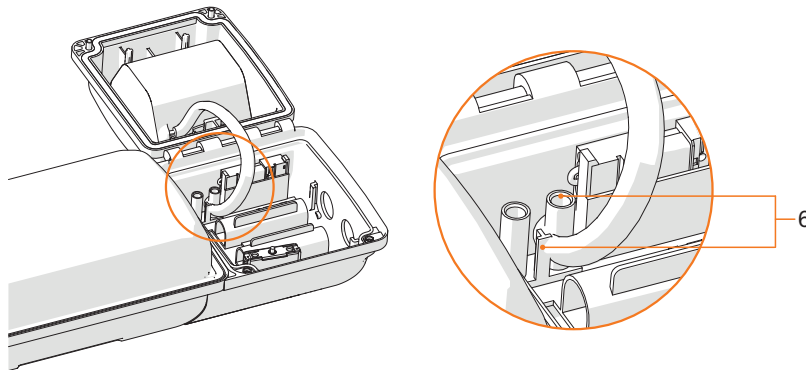

21447E00

- Close the battery case. Fix battery conductors in place to protect them against getting caught between the plastic domes (6).
- Tighten the screws (1) (cross head H2) firmly (2 Nm).

## Resetting the error indication "blinking red" after replacing the battery

<b>i</b>	<p>The error indication "blinking red" remains active after successfully replacing the battery.</p> <p><b>Deactivation:</b></p> <p>Automatic:</p> <ul style="list-style-type: none"> <li>• After replacing the battery a rated operating time test is carried out automatically within 14 days.</li> <li>• The error will be reset once this test has been passed successfully.</li> </ul> <p>Manual:</p> <ul style="list-style-type: none"> <li>• The line voltage must be switched on.</li> <li>• Actuate the switch in the battery case for 5 seconds.</li> <li>• Release the switch.</li> <li>• Actuate the switch twice within 10 seconds for a duration of 2 seconds.</li> <li>• Resetting of the error will be shown on the LED indicator for 5 seconds by blinking red/green.</li> <li>• The error is reset.</li> <li>• Close the battery case.</li> </ul>
----------	--

### 11.2 Repair

Repairs carried out on the mounting plate are not permitted.  
Replace the mounting plate completely in case of malfunction.

### 11.3 Returning the device

- Only return or package the devices after consulting R. STAHL!  
Contact the responsible representative from R. STAHL.

R. STAHL's customer service is available to handle returns if repair or service is required.

- Contact customer service personally.

or

- Go to the [r-stahl.com](http://r-stahl.com) website.
- Under "Support" > "RMA" > select "RMA-REQUEST".
- Fill out the form and send it.  
You will automatically receive an RMA form via email. Please print this file off.
- Send the device along with the RMA form in the packaging to  
R. STAHL Schaltgeräte GmbH (refer to chapter 1.1 for the address).

## 12 Cleaning

- Clean the device only with a cloth, brush, vacuum cleaner or similar items.
- When cleaning with a damp cloth, use water or mild, non-abrasive, non-scratching cleaning agents.
- Do not use aggressive detergents or solvents.
- Never clean the device with a strong water jet, e.g. using a high-pressure washer!

## 13 Disposal

- Observe national and local regulations and statutory regulation regarding disposal.
- Separate materials when sending it for recycling.
- Ensure environmentally friendly disposal of all components according to the statutory regulations.
- Removal of components at the end of their service life:
  - Remove and open luminaires according to the operating instructions.
  - Disconnect cables from the LED PCB and control gear.
  - Control gear: Loosen the mounting screws and remove the device.
  - LED PCB: Push the barbs on the underside together using suitable pliers and remove the PCB upwards.

CAUTION	
	<p>Danger due to chemical reactions! Human health and the environment are at risk!</p> <p>Batteries</p> <ul style="list-style-type: none"> <li>• collect them separately</li> <li>• dispose of them in controlled fashion</li> <li>• do not dispose of them in the domestic waste</li> <li>• return them to public collection points or to the supplier</li> </ul>

## 14 Accessories and Spare parts

NOTICE	
<p>Malfunction or damage to the device due to the use of non-original components. Non-compliance can result in material damage.</p> <ul style="list-style-type: none"> <li>• Use only original accessories and spare parts from R. STAHL Schaltgeräte GmbH.</li> </ul>	

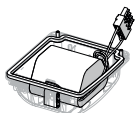
Figure	Description	Art. no.	Weight kg
 16332E00	Battery cover with built-in battery. Gas-tight NiCd battery; 7 Ah / 6 V	223532	1.195

	<p>For accessories and spare parts, see data sheet on our homepage <a href="http://r-stahl.com">r-stahl.com</a>.</p>
---	--

**EU-Konformitätserklärung**  
*EU Declaration of Conformity*  
*Déclaration de Conformité UE*



**R. STAHL Schaltgeräte GmbH • Am Bahnhof 30 • 74638 Waldenburg, Germany**  
 erklärt in alleiniger Verantwortung, *declares in its sole responsibility, déclare sous sa seule responsabilité,*

dass das Produkt: **LED Notlichtleuchte**  
*that the product: LED Emergency Luminaire*  
*que le produit: LED Luminaire de secours*

Typ(en), type(s), type(s): **L409/4...**

mit den Anforderungen der folgenden Richtlinien und Normen übereinstimmt.  
*is in conformity with the requirements of the following directives and standards.*  
*est conforme aux exigences des directives et des normes suivantes.*

Richtlinie(n) / Directive(s) / Directive(s)		Norm(en) / Standard(s) / Norme(s)
<b>2014/35/EU</b> 2014/35/EU: 2014/35/UE:	<b>Niederspannungsrichtlinie</b> <i>Low Voltage Directive</i> <i>Directive Basse Tension</i>	EN 60598-1:2015 + A1:2018 EN 60598-2-22:2014 + A1:2020 EN 62471:2008
<b>2014/30/EU</b> 2014/30/EU 2014/30/UE	<b>EMV-Richtlinie</b> <i>EMC Directive</i> <i>Directive CEM</i>	EN IEC 55015:2019 + A11:2020 EN 61547:2009 EN 61000-3-2:2014 EN 61000-3-3:2013
<b>2011/65/EU</b> 2011/65/EU 2011/65/UE	<b>RoHS-Richtlinie</b> <i>RoHS Directive</i> <i>Directive RoHS</i>	EN IEC 63000:2018
<b>2009/125/EG</b> 2009/125/EC 2009/125/CE	<b>Ökodesign</b> <i>Ecodesign</i> <i>Écoconception</i>	EU 2019/2020 EU 2021/341

Waldenburg, 2021-11-05

**Ort und Datum**  
*Place and date*  
*Lieu et date*

i.V.

  
**Dr. C. Chevalier**  
*Vice President BU Lighting & Signalling*  
*Vice-Président BU Eclairage & Appareils de signalisation*

i.V.

  
**J. Freimüller**  
*Vice President global Quality Management*  
*Vice-Président globale Gestion de Qualité*

**UK Declaration of Conformity**  
*UK-Konformitätserklärung*



**R. STAHL Schaltgeräte GmbH • Am Bahnhof 30 • 74638 Waldenburg, Germany**  
 represented locally by, *lokal vertreten durch*  
**R. STAHL LTD. • 2nd Floor, Bromwich Court, Gorse Lane, Coleshill • Birmingham B46 1JU, UK**  
 declares in its sole responsibility, *erklärt in alleiniger Verantwortung,*

that the product: **LED Emergency Luminaire**  
*dass das Produkt:* **LED Notlichtleuchte**  
 Type(s), *Typ(en):* **L409/4...**

is in conformity with the requirements of the following regulations and standards.  
*mit den Anforderungen der folgenden Verordnungen und Normen übereinstimmt.*

Regulation(s) / <i>Verordnung(en)</i>	Standard(s) / <i>Norm(en)</i>
<b>S.I. 2016/1101 Electrical Equipment (Safety) Regulation</b> <i>S.I. 2016/1101 (Sicherheits-) Verordnung für elektronische Geräte</i>	EN 60598-1:2015 + A1:2018 EN 60598-2-22:2014 + A1:2020 EN 62471:2008
<b>S.I. 2016/1091 EMC Regulations</b> <i>S.I. 2016/1091 EMV-Verordnung</i>	EN IEC 55015:2019 + A11:2020 EN 61547:2009 EN 61000-3-2:2014 EN 61000-3-3:2013
<b>S.I. 2012/3032 RoHS Regulations</b> <i>S.I. 2012/3032 RoHS-Verordnung</i>	EN IEC 63000:2018
<b>S.I. 2010/2617 Ecodesign</b> <i>S.I. 2010/2617 Ökodesgin</i>	UK 2021/1095

Waldenburg, 2022-12-07

**Place and date**  
*Ort und Datum*

i.V.

**S. Holtz**  
**Head of R&D - BU Lighting & Signalling**  
*Leiter Entwicklung Leuchten und Signalgerät*

i.V.

**D. Groth**  
**Quality Manager**  
*Qualitätsmanager*