



# Operating Instructions

**ProVicom Eagle MT-3x6-S-Tx, MT-3x6-S-Fx**  
(valid for HW Revision 2., 4<sup>th</sup> Supplement)

---

R. STAHL HMI Systems GmbH  
Im Gewerbegebiet Pesch 14  
50767 Köln

HW-Rev. MT-3x6-S-Tx: 02.04.23  
HW-Rev. MT-3x6-S-Fx: 02.04.13

Operating instructions version: 02.04.08  
Issue: 29.08.2011

## Table of contents

	Description	Page
	Table of contents	2
1	Preface	4
2	Device function MT-3x6-S-Tx, MT-3x6-S-Fx	4
2.1	Keyboard features	4
3	Technical details	5
4	Conformity to standards	6
5	Certifications	7
5.1	ATEX	7
5.2	DNV	7
5.3	GOST-R	7
5.4	CNEX	7
5.5	CKT	7
5.6	UL	7
6	Product identification	8
7	Power supply	8
7.1	Operator interfaces	8
7.1.1	All circuits in zone 2	8
7.1.2	With circuits in zone 1	8
7.2	Reader modules	9
8	Permitted maximum values	9
8.1	External, non-power limited safe circuits	9
8.2	External inherently safe optical interface	9
8.3	Outer intrinsically safe circuits	10
9	Type code	12
10	Safety Advice	13
10.1	Installation and operation	13
10.2	Special conditions	14
10.3	Circuits in zone 21	14
10.4	Installation via USB interfaces	14
10.4.1	Software installation using a USB Memory Stick	14
10.4.2	Software installation with external USB devices	14
10.5	USB interfaces	15
10.5.1	USB0 and USB2 interfaces	15
10.5.2	USB1 and USB3 interfaces	15
10.5.2.1	Connection versions for USB interfaces	15
10.5.2.2	Terminals	15
11	Installation	17
11.1	General information	17
11.2	MT-3x6-S-Tx, MT-3x6-S-Fx	17
12	Assembly and disassembly	18
12.1	General information	18
12.2	Cut-out MT-3x6	18
13	Operation	18
13.1	General information	18

<b>13.2</b>	<b>Connections MT-3x6</b>	<b>19</b>
<b>13.2.1</b>	<b>Dip switch settings S3 and S4</b>	<b>20</b>
<b>13.3</b>	<b>Connections Ex-e terminals (X12)</b>	<b>21</b>
<b>13.3.1</b>	<b>Labelling I.S. circuits</b>	<b>21</b>
<b>13.3.2</b>	<b>Connection details of the I.S. or Ex-nL terminals</b>	<b>21</b>
<b>13.3.3</b>	<b>Connection details of the Ex-e terminals</b>	<b>21</b>
<b>13.3.4</b>	<b>Cable types and cross sections</b>	<b>21</b>
<b>14</b>	<b>Maintenance, service</b>	<b>22</b>
<b>14.1</b>	<b>Servicing</b>	<b>22</b>
<b>14.2</b>	<b>Data storage</b>	<b>22</b>
<b>14.3</b>	<b>Time function</b>	<b>22</b>
<b>15</b>	<b>Troubleshooting</b>	<b>22</b>
<b>16</b>	<b>Disposal</b>	<b>23</b>
<b>16.1.1</b>	<b>ROHS directive 2002/95/EC</b>	<b>23</b>
<b>16.1.2</b>	<b>China ROHS labeling</b>	<b>23</b>
<b>17</b>	<b>Front panel resistance</b>	<b>24</b>
<b>17.1</b>	<b>Design</b>	<b>24</b>
<b>17.2</b>	<b>Materials</b>	<b>25</b>
<b>17.3</b>	<b>Material properties</b>	<b>25</b>
<b>17.3.1</b>	<b>Entire device</b>	<b>25</b>
<b>17.3.2</b>	<b>Membrane top</b>	<b>26</b>
<b>17.3.3</b>	<b>Display / Touch screen</b>	<b>28</b>
<b>17.3.4</b>	<b>Front panel seal</b>	<b>28</b>
<b>18</b>	<b>UL Certification</b>	<b>29</b>
<b>18.4</b>	<b>Device with UL certification</b>	<b>31</b>
<b>18.5</b>	<b>Control Drawings</b>	<b>32</b>
<b>19</b>	<b>Accessories</b>	<b>35</b>
<b>19.1</b>	<b>Phoenix Contact terminal block</b>	<b>35</b>
<b>19.1.1</b>	<b>Data sheet Mini-Ex-terminal</b>	<b>35</b>
<b>20</b>	<b>Declaration of EC conformity</b>	<b>38</b>
<b>21</b>	<b>Release Notes</b>	<b>39</b>

## 1 Preface

These operating instructions are intended for the safe installation of the Eagle series operator interfaces and cover all Ex-relevant aspects. Furthermore, these operating instructions contain all necessary information for assembly and connection of the operator interfaces.



For the correct operation of all associated components please note, in addition to these operating instructions, all other operating instructions enclosed in this delivery as well as the operating instructions of the additional equipment to be connected.



Please also note that all certificates of the operator interfaces can be found in a separate document !

## 2 Device function MT-3x6-S-Tx, MT-3x6-S-Fx

The MT-3x6-S-Tx / MT-3x6-S-Fx operator interfaces are intelligent visualization systems for automation applications. In line with ATEX directive 94/9/EC they may also be installed in hazardous areas of zones 2 and 22.

The devices may be fitted in control cabinets, panels etc.

Users operate the device via the membrane keyboard integrated into the front plate and via the LCD display with touch screen.

The operator interfaces communicated with control and automation systems via the serial interfaces (RS-232, RS-422/485, Ethernet) located in the connection box at the rear of the devices. Various peripheral devices, such as barcode scanners, card readers, USB sticks and WLAN / Bluetooth modules can be connected via USB interfaces or optional fitted modules.

With a wealth of functions, these operator interfaces provide optimum visualization. Their active communication concept in combination with integrated functionality reduce the automation system workload.

In terms of software and functionality, the MT-3x6-S-Tx / MT-3x6-S-Fx operator interfaces are compatible with their predecessors, the MT-315 and MT-335.

### 2.1 Keyboard features



Pressing two keys at once (e.g. F1 + F7) is not supported by the operator interfaces ! In such a case, the system considers the key that was pressed first as "active" and implements the associated functions and / or key bit functions ! The key pressed second is ignored.



Pressing any three of the following keys at the same time has the same effect as pressing Ctrl + Alt + Del ! The keys are: F1, F2, F7 and F8.



MT-306 only:

The S1 – S10 softkeys can **NOT** be used in combination with Shift / Alt / Ctrl ! The system will only execute the original key command.

### 3 Technical details

			
Function / Equipment	MT-306-S	MT-316-S	MT-336-S
Display type	TFT Color, 64k colors		
Display size	26 cm (10.4")		38 cm (15")
Resolution	VGA, 640 x 480 pixels	SVGA, 800 x 600 pixels	XGA, 1024 x 768 pixels
Display	Touch screen on glass		
Touch Screen	8-wire analogue resistive		
Lighting	CFL backlight		
Service life of backlight at 25°C	50,000h		
Brightness	350 cd/m <sup>2</sup>		250 cd/m <sup>2</sup> (option 600 cd/m <sup>2</sup> )
Keyboard	Polyester membrane on FR4 material; > 1 million actions		
Functional keys	12	12	8
Freely assignable / number			
Soft keys	Yes / 12	no	no
Cursor keys	10	no	no
Alphanumeric keys	Yes	no	no
Numeric keys	23	no	no
	Yes	no	no
Real time clock / Data buffer	Yes (capacitor buffered, maintenance-free) / > 4 days		
Interfaces			
Communication COM1 and COM2	RS-232, RS-422, RS-485		
Fieldbus	Profibus with 9185/12-46-10 MPI with MPI Box SSW7-RK512-RS-422		
Ethernet	Alternatively Tx or Fx		
Copper (Tx)	10/100BaseTx, 10/100 Mbit, increased safety (Ex-e)		
Optical fiber (Fx)	100BaseFx, 100 Mbit, inherently safe (Ex op is)		
Cable type optical fiber	Multimode optical fiber cable with 62.5 µm core diameter and 125 µm outer diameter		
USB	2x Ex-nA and 2x Ex-i (or Ex-nL)		
PS/2	For external keyboard (option) or mouse (option), both I.S. (or Ex-nL)		
Readers (option)	Connection for: Barcode scanner, Wiegand reader, Proximity reader		
Processor	LX 800, 300 MHz		
Main memory [Mbyte]	256		
Data memory [Mbyte]	256		
Operating system	RT Target		
Languages	Global, multilingual language support		
Number of protocol drivers	A maximum of 4 simultaneously		
Number of process images	> 1000 dynamic		
Number of texts / messages	Dynamically limited by main memory		
Number of variables per page	255		
Number of messages	4096 fault messages, 4096 operation messages		
Font sets	4 independent Windows uncondensed fonts		
Configuration memory type	Compact flash card		
Power supply	24 VDC (20.4 up to 28.8 VDC)		
Power consumption [A]	1.9	1.9	1.9
Connections	Via plug-in screw terminals, 2.5 mm <sup>2</sup> green		
Max. operating voltage U <sub>m</sub>	30 VDC for circuits in zone 1		
Housing	Stainless steel		
Front plate	Aluminum with polyester membrane, touch and safety glass		
Protection type	IP66 (according to EN 60529)		
Temperature range			
Cold start temperature	-10...+55°C		
During operation	-20...+55°C		
Operating with heater *	-30...+55°C		
Operating with heater *, housing insulation and front cover	-40...+55°C		
Storage temperature	-20...+60°C		
* Comment	The used heater must be construed in the way, that inside of the enclosure of the operator interface the temperature will <b>NOT</b> fall below -20°C (-30°C only front plate) !		

Relative humidity	90% at 40 °C, without condensation		
Vibration			
Operation	3 to 22Hz: 1mm 22 to 500Hz: 9.8m/s <sup>2</sup> = 1g		
Transport	3 to 9Hz: 3.5mm 9 to 500Hz: 9.8m/s <sup>2</sup> = 1g		
Shock loading			
Operation	150m/s <sup>2</sup> = ca. 15g / 11ms		
Transport	250m/s <sup>2</sup> = ca. 25g / 6ms		
Dimensions [mm]			
Front (w x h)	400 x 270	372 x 270	440 x 340
Cut-out (w x h) (+/- 0.5)	385.5 x 257.5	359.5 x 257.5	427.5 x 327.5
Mounting depth	150		165
Wall thickness	8		
Weight [kg]			
Operator interface	11.55	11.55	14.7
Fixing frame	0.6	0.6	0.7

## 4 Conformity to standards

The MT-3x6-S-Tx / MT-3x6-S-Fx operator interfaces comply with the following standards and directives:

Standard	Classification
<b>Directive 94/9/EC</b>	
<b>4<sup>th</sup> Supplement</b>	
EN 60079-0 : 2006	General requirements
EN 60079-1 : 2007	Flameproof enclosures "d"
EN 60079-7 : 2007	Increased safety "e"
EN 60079-11 : 2007	Intrinsic safety "i"
EN 60079-15 : 2005	Protection "n"
EN 60079-18 : 2004	Encapsulation "m"
EN 60079-28 : 2007	Optical radiation
EN 61241-0 : 2006	General requirements (dust)
EN 61241-1 : 2004	Protection by enclosures "tD" (dust)
EN 61241-11 : 2006	Intrinsic safety "iD" (dust)
<b>Electromagnetic compatibility</b>	
<b>Directive 2004/108/EC</b>	
EN 61000-6-2 (2005)	Immunity
EN 61000-6-4 (2007)	Emission

## 5 Certifications

The Eagle operator interfaces have been approved for the following scopes:

By ATEX directive 94/9/EC

for installation in zones 2 und 22

DNV (Det Norske Veritas)

GOST-R (Russian certification)

CNEX (Nanyang Explosion Protected Electrical Apparatus Research Institute – Chinese certification)

CKT (CAA JSC The National Center of Expertise and Certification Almaty Branch – Kazakh certification)

UL (Underwriters Laboratories)

### 5.1 ATEX

The ATEX certification is listed below the following number:

Certificate number: TÜV 07 ATEX 7471 X

### 5.2 DNV

The DNV certification is listed below the following numbers:

Certificate number: A-11822  
File number: 899.60  
Job Id: 262.1-001689-3

### 5.3 GOST-R

The GOST-R certification is listed below the following number:

Certificate number: POCC DE.ГБ04.В01280

### 5.4 CNEX

The CNEX certification is listed below the following number:

Certificate number: CNEx10. 1832X

### 5.5 CKT

The CKT certification is listed below the following numbers:

Certificate number: KCC No 1018112  
KZ.0.02.0317  
KZ.7500317.01.01.14106

### 5.6 UL

The UL certification is listed below the following number:

UL File Number: E202379

## 6 Product identification

Manufacturer	R. STAHL HMI Systems GmbH	
Type code	MT-3x6-S-Tx / MT-3x6-S-Fx	
CE classification:	CE 0158	
Testing authority and certificate number:	TÜV 07 ATEX 7471 X	
Ex classification:		
ATEX-directive 94/9/EC		II 3 (3) G Ex d e mb nA nL [nL] [op is] IIC T4 II 3 (2) G Ex d e mb nA nL [ib] [op is] IIC T4 II 3 (2) D Ex tD A22 IP65 [ibD] T90°C
GOST-R		2ExdemnL[ib]sIICT4X 2ExdemnL[nL]sIICT4X DIP A22 TA90°C, IP65
CNEX		ExdembnAnL[ib]IICT4 DIP A22 TA, T90°C
UL		Class I, Div. 2, Groups A, B, C, D Class II, Div. 2, Groups F, G Class III, hazardous locations Class I, Zone 2, Group IIC Temperature classification T4, enclosure type 1

## 7 Power supply

### 7.1 Operator interfaces

Power supply: 24.0 VDC (min. 20.4 VDC; max. 28.8 VDC)  
Um = 30 VDC  
(for connected circuits in zone 1)

Power consumption: max. 1.9 A

#### 7.1.1 All circuits in zone 2

If the operator interface and all connected circuits are solely used in zone 2, the operator interface can be supplied with the required rated voltage of

$$U_{\text{rated}} = 24 \text{ VDC (+20\% / -15\%)}$$

Operation is in accordance with the label II 3 (3) G Ex d e mb nA nL [nL] [op is] IIC T4.

#### 7.1.2 With circuits in zone 1

If the operator interface is run in zone 2 and connected to intrinsically safe circuits / devices in zone 1, the following applies:

$$U_m = 30 \text{ VDC}$$

(see EN 60079-11 : 2007, section 3.16).

Operation is in accordance with the label II 3 (2) G Ex d e mb nA nL [ib] [op is] IIC T4.



## 7.2 Reader modules

- a) WCR1 external power supply module with limited (Ex-nL) or intrinsically safe (I.S.) power supply circuit
- b) RSi1 internal limited (Ex-nL) or intrinsically safe (I.S.) power supply circuit

☞ Please refer to [section 8.3](#) for the relevant connection values for a and b.

## 8 Permitted maximum values

### 8.1 External, non-power limited safe circuits

Input voltage (X1):

Rated voltage	24 VDC (+20% / -15%) (for exclusive operation in zone 2)	
Power consumption for $U_{rated}$	1.9 A max	
Max. operating voltage $U_m$	30 VDC (applies for connected circuits in zone 1)	

RS-422/-232 COM 1 (X2):

Rated voltage	RS-422: 5 VDC	RS-232: $\pm 12$ VDC
Max. operating voltage $U_m$	253 VAC	

RS-422/-232 COM 2 (X3):

Rated voltage	RS-422: 5 VDC	RS-232: $\pm 12$ VDC
Max. operating voltage $U_m$	253 VAC	

USB-1 (X5):

Rated voltage	5 VDC
Max. operating voltage $U_m$	253 VAC

USB-3 (X7):

Rated voltage	5V DC
Max. operating voltage $U_m$	253 VAC

Ethernet copper (X11):

Rated voltage	5 VDC
Rated power	100 mW

### 8.2 External inherently safe optical interface

Ethernet optical fiber (X10):

Wavelength	1350 nm
Radiant power	$\leq 35$ mW



Reader WCR1 (power supply Reader, X8.3-4):

The maximum values for group IIC are:

$U_i$	=	-	V		$U_o$	=	5.88	V
$I_i$	=	-	mA		$I_o$	=	200	mA
$P_i$	=	-	mW		$P_o$	=	1.18	W
$C_i$	=	4.6	$\mu$ F		$C_o$	=	28.4	$\mu$ F
$L_i$	=	100	nH		$L_o$	=	1.9	$\mu$ H

Reader WCR1 (signal input / output, X8.5-8):

The maximum values for group IIC are:

$U_i$	=	15	V		$U_o$	=	5.88	V
$I_i$	=	500	mA		$I_o$	=	56	mA
$P_i$	=	2.5	W		$P_o$	=	83	mW
$C_i$	=	0	$\mu$ F		$C_o$	=	34	$\mu$ F
$L_i$	=	0	mH		$L_o$	=	2	$\mu$ H

Reader RSi1 (connection voltage supply, X8.1-2):

The maximum values for group IIC are:

$U_i$	=	12.4	V		$U_o$	=	-	V
$I_i$	=	220	mA		$I_o$	=	-	mA
$P_i$	=	2.7	W		$P_o$	=	-	mW
$C_i$	=	0	$\mu$ F		$C_o$	=	-	$\mu$ F
$L_i$	=	0	mH		$L_o$	=	-	mH

Reader RSi1 (power supply Reader, X8.3-4):

The maximum values for group IIC are:

$U_i$	=	-	V		$U_o$	=	5.4	V
$I_i$	=	-	mA		$I_o$	=	220	mA
$P_i$	=	-	W		$P_o$	=	1.19	W
$C_i$	=	4.2	$\mu$ F		$C_o$	=	39.8	$\mu$ F
$L_i$	=	100	nH		$L_o$	=	1.9	$\mu$ H

Reader RSi1 (signal input / output, X8.5-8):

The maximum values for group IIC are:

$U_i$	=	15	V		$U_o$	=	5.4	V
$I_i$	=	500	mA		$I_o$	=	49	mA
$P_i$	=	2.5	W		$P_o$	=	62	mW
$C_i$	=	0	$\mu$ F		$C_o$	=	45	$\mu$ F
$L_i$	=	0	mH		$L_o$	=	2	$\mu$ H

PS2 interface (X9):

Connection for keyboard, mouse, trackball, joystick

The maximum values for group IIC are:

$U_i$	=	-	V		$U_o$	=	5.9	V	
$I_i$	=	-	mA		$I_o$	=	200	mA	
$P_i$	=	-	mW		$P_o$	=	1.18	W	
$C_i$	=	14	$\mu$ F		$C_o$	=	19	29	$\mu$ F
$L_i$	=	0	mH		$L_o$	=	2	1	$\mu$ H

$C_o$  and  $L_o$  pairs directly above/underneath each other may be used.

☞ Do **NOT** connect the optional external keyboard to live equipment !

## 9 Type code

Basic device:

ProVicom MT-xxx

306 / 316 / 336

Product type:

Version	Description
	Type with
MT-xxx-S-Fx	Optical fiber Ethernet interface 100BaseFx (Ex op is)
MT-xxx-S-Tx	Copper Ethernet interface 10/100BaseTx (Ex-nA)
MT-xxx-S-RSi	Module for reader unit with integrated decoder and RS-232 interface
MT-xxx-S-WCRi	Module for reader unit with Wiegand interface
MT-3x6-xx-UL	Operator interface with UL certification (May <b>ONLY</b> be used in ATEX areas with cable glands instead of Conduit Hubs !)*

\*  See note in section "UL certification" !

## 10 Safety Advice

This chapter is a summary of the key safety measures. The summary is supplementary to existing rules which staff also have to study.

The safety of persons and equipment in hazardous areas depends on compliance with all relevant safety regulations. Thus, the installation and maintenance staff carry a particular responsibility, requiring precise knowledge of the applicable regulations and conditions.

### 10.1 Installation and operation

Please note the following when installing and operating the device:

- Only operator interfaces with UL certification may be installed and operated in areas covered by the NEC (see chapter "UL certification") !  
In areas covered by ATEX, this device may **ONLY** be installed and operated if the two Conduit Hub connections have been replaced by conventional cable glands !
- The national regulations for installation and assembly apply (e.g. EN 60079-14).
- The operator interfaces may be installed in zones 2 or 22.
- The installation must be compliant with any applicable regulations.
- The operator interface must only be switched on when it is closed.
- After switching the operator interface off, wait for at least 1 minute before opening it.
- The safe maximum values of the connected field device(s) must correspond to the values listed on the data sheet.
- When used in zone 2 and zone 22, intrinsically safe category 2 devices or energy-limited category 3 associated equipment may be connected to the intrinsically safe circuits.
- If category 2 equipment is connected to the intrinsically safe circuits in zone 1, Um must adhere to EN 60079-11 : 2007, section 3.16 when connecting the power supply and the non-energy-limited circuits of the ProVicom MT-3x6.
- For the maximum connectable L and C values of the intrinsically safe circuits, the associated (above/underneath each other) pairs of values must be applied.
- Ex-e, Ex-nL or I.S. circuits **MUST NOT** be connected at the same time on terminal block X12.
- The external leads of the operator interfaces must not be connected under strain.
- National safety and accident prevention rules.
- Generally accepted technical rules.
- Safety instructions contained in these operating instructions.
- Any damage may compromise the explosion protection !

Use the keyboard for its intended purpose only (see "Function").

Incorrect or unauthorized use and non-compliance with the instructions in this manual will void any warranty on our part.

No changes may be made to the operator interface or its components that compromise explosion protection !

The operator interface may only be installed and operated in an undamaged condition !

## 10.2 Special conditions

- The housing of the operator interface must be protected against prolonged UV radiation.
- The operator interface and any connected equipment must be incorporated into the same potential equalization system (see installation example in the Hardware Manual). An alternative would be to connect only devices that are safely isolated from earth potential.

## 10.3 Circuits in zone 21

It is permitted to connect intrinsically safe circuits of "ibD" protection type in zone 21.

## 10.4 Installation via USB interfaces

Installation of software on the operator interfaces:

### 10.4.1 Software installation using a USB Memory Stick

You may only use USB memory sticks permitted for use by R. STAHL HMI Systems GmbH. These USB memory sticks are below and in general referred to by R. STAHL HMI Systems GmbH as "USB(i) Drives". Data may only be copied onto the operator interfaces and software may only be installed with these USB Drives.

- In hazardous areas, you may only use Ex-i certified memory sticks supplied by R. STAHL HMI Systems GmbH.
- In an industrial area, a permitted, non-ex memory stick may be connected to the current-limited USB interface of the operator interface after having been connected to any PC.
- R. STAHL HMI Systems GmbH's USB(i) drives may also be connected to non-intrinsically safe interfaces and can be used with the MT-3x6 series operator interfaces when connected to such interfaces.

If devices are connected to the power-limited USB interfaces that have not been approved by R. STAHL HMI Systems GmbH, protective elements may become damaged, thus compromising the current limiting of the interfaces.

In this case R. STAHL HMI Systems GmbH can no longer guarantee the current limiting of the device.

### 10.4.2 Software installation with external USB devices

Software may be installed with the aid of any external USB devices subject to the following conditions:

- The software is installed in the safe area.
- the USB devices are connected to the USB interfaces (USB1 or USB3 – X5 or X7) with the VB-USB-INST1 connection cable.

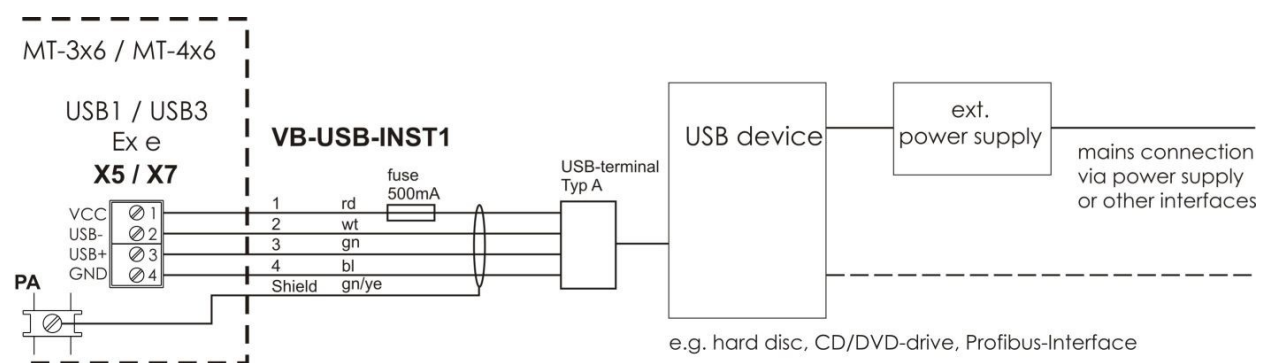

Connection diagram with VB-USB-INST1 (hard disk, CD/DVD with power supply)

## 10.5 USB interfaces

The MT-3x6 operator interfaces have 2 USB interface channels.

- Channel 1 is wired in parallel to USB0 (X4) and USB2 (X6) and can be used for the internal (X4) or external (X6) connection of an USB Drive.
- Channel 2 is wired in parallel to USB1 (X5) and USB3 (X7) and can be used to connect an external USB device.

 The connection diagram for the MT-3x6 interfaces can be found in [chapter 13.2, connections MT-3x6](#).

### 10.5.1 USB0 and USB2 interfaces

The USB0 and USB2 I.S. USB interfaces (X4 and X6) are intended for the internal or external connection of USB Drives.

The maximum value for the joint power supply of USB0 and USB2 is 500 mA.

### 10.5.2 USB1 and USB3 interfaces

The USB1 and USB3 interfaces (X5 and X7) are intended for the connection of external USB devices.

The maximum value for the joint power supply of USB1 and USB3 is 500 mA.

#### 10.5.2.1 Connection versions for USB interfaces

Both USB1 and USB3 interfaces have an identical structure.



If intrinsically safe devices are connected to the non-intrinsically safe USB interfaces of the MT-3x6 operator interfaces, R. STAHL HMI Systems GmbH can no longer guarantee the intrinsic safety of these devices !

The following versions are possible:

1. If a USB device that is not connected to the mains is connected, voltage can be supplied from the internal power supply (terminal 1).
2. If a USB device that is connected to the mains is connected, the internal power supply (terminal 1) must **not** be connected. The power must then be supplied externally.
  - The interrupting capacity of the fuses of the internal USB power supplies is 1.5 kA.
  - The tripping characteristic of the fuses is T (time-lag, type T fuse)
  - The USB accessory parts are fitted inside an appropriate housing.

#### 10.5.2.2 Terminals

Flexible cables of between 0.2 – 2.5 mm<sup>2</sup> may be connected to the X5 and X7 terminals.

The maximum cable length for the connection with the USB interfaces (X5 and X7) is 2.5 m.

The insulation of the wire must reach right up to the terminal body.

10.5.2.2.1 Type 1 connection version

- The USB device does not require an external power supply as it uses less than 500 mA.
- No connection to the mains via any other terminals.

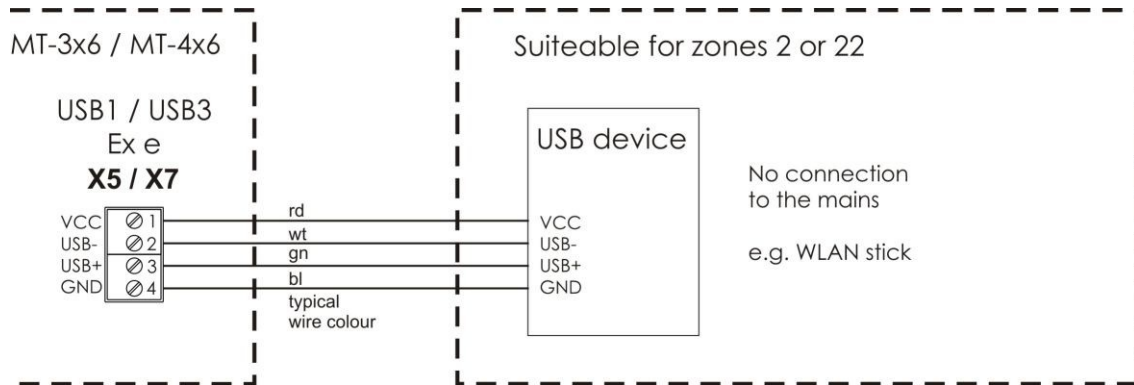

Connection diagram type 1

10.5.2.2.2 Type 2 connection version

- The USB device does require an external power supply to function because it uses over 500 mA, e.g. hard disks, CD/DVD drives.
- The USB device is connected to the mains via other interfaces, e.g. USB/serial converter, USB-Profibus interface.

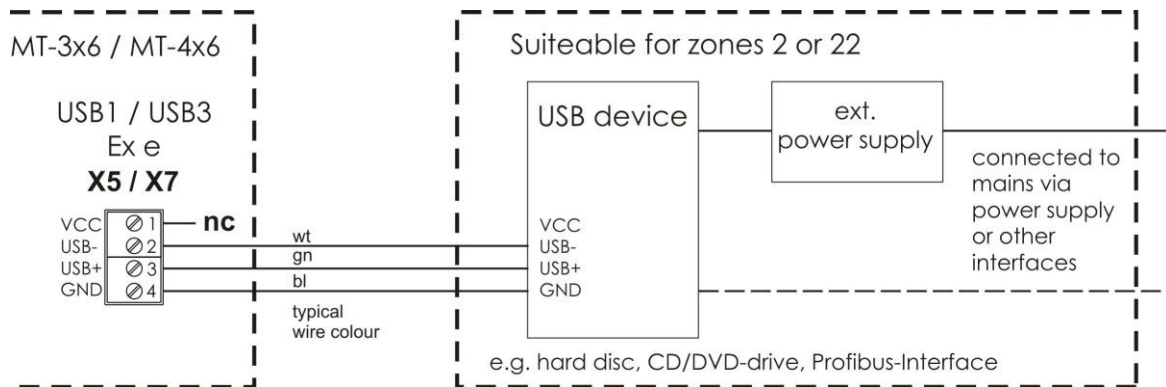

Type 2 connection diagram (e.g. hard disk, CD/DVD with power supply)



10.5.2.2.3 Type 3 connection version

- The USB device does require an external power supply to function because it uses over 500 mA, e.g. hard disks, CD/DVD drives.
- The USB device is connected to the mains via other interfaces, e.g. USB/serial converter, USB-Profibus interface.
- The USB device needs the VCC connection of the operator interface (internal supply – terminal 1) to function.

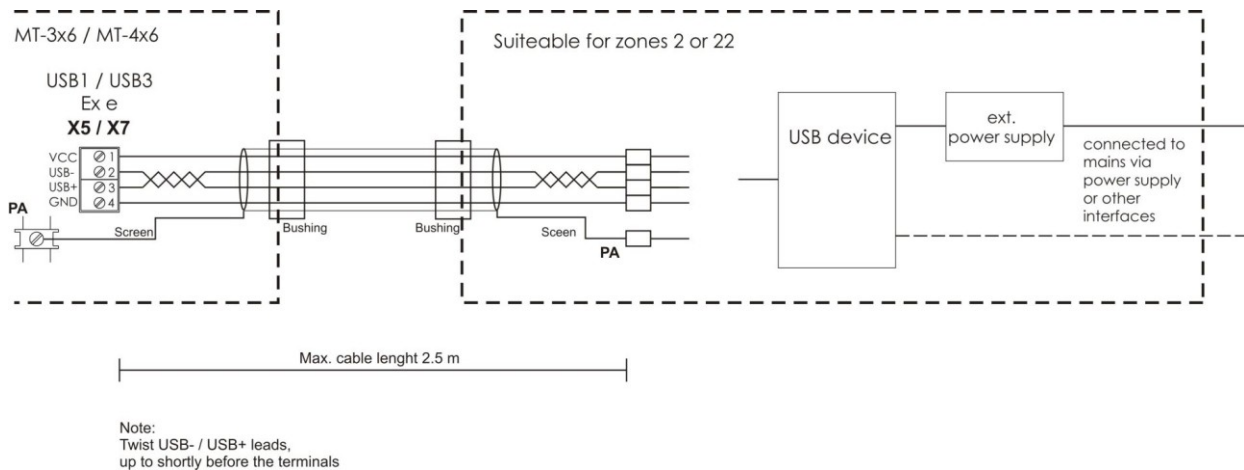

Type 3 connection diagram (any USB device with power supply)

# 11 Installation

## 11.1 General information

Electrical installations are subject to the relevant regulations for installation and operation, such as RL 1999/92/EC, RL 94/9/EC und IEC/EN 60079-14.

The operators of electrical installations in hazardous environments must ensure that the equipment is kept in proper condition, is operated according to instructions and that maintenance and repairs are carried out.

## 11.2 MT-3x6-S-Tx, MT-3x6-S-Fx

- The operator interfaces may be installed in zones 2 or 22. The circuits must be installed according to applicable regulations.
- The operator interfaces may be mounted in any position.
- The PA connector of the operator interface, located at the back of the housing, is internally connected to the GND supply cable (X1, pins 3 and 4).
- Ex-e terminal blocks (X12) may be mounted inside the connection box of the housing (**NOT** NEC). They can, for example, serve as a sub-distribution unit for supply and signal lines of accessories mounted in separate housings and connected to the operator interface. These terminal blocks are installed during production of the operator interface. Customers must not attempt to mount the blocks into the devices themselves.
- The operator interface's front should be protected by a canopy against permanent exposure to UV light. This increases the front membrane's lifespan. The canopy **MUST NOT** be too close to the front plate and sufficient air circulation must be ensured.

## 12 Assembly and disassembly

### 12.1 General information

Assembly and disassembly are subject to general technical rules. Additional, specific safety regulations apply to electronic and pneumatic installations.

### 12.2 Cut-out MT-3x6

Make a cut-out with the following dimensions:

Operator interface	Width	Height	Depth of cut-out	Material thickness
MT-306-S	385.5 ± 0.5 mm	257.5 ± 0.5 mm	150 mm	up to 8 mm
MT-316-S	359.5 ± 0.5 mm	257.5 ± 0.5 mm	150 mm	up to 8 mm
MT-336-S	427.5 ± 0.5 mm	327.5 ± 0.5 mm	165 mm	up to 8 mm

## 13 Operation

### 13.1 General information

When operating the devices, particular care shall be taken that:

- the operator interface has been properly installed according to instructions,
- the device is undamaged,
- the terminal compartment is clean,
- all screws are tightened fast,
- the screws on the cable inlets are tightened fast,
- before switching the operator interface on, its external bonding terminal (PA-connector) is properly connected to the equipotential bonding system at its place of use,
- the cover of the terminal compartment is completely closed,
- there is no strain on any of the cables.

### 13.2 Connections MT-3x6

Terminal	Pin	Definition	Connection
X1	1	Power supply operator interface +24 VDC	Power supply of the operator interface
	2	Power supply operator interface +24 VDC	
	3	Power supply operator interface GND	
	4	Power supply operator interface GND	
X2	1	TxD-b	Serial COM1 interface RS-422/485
	2	TxD-a	
	3	RxD-b	
	4	RxD-a	
	5	TxD-b'	
	6	TxD-a'	
	7	RxD-b'	
	8	RxD-a'	
	9	TxD	Serial COM1 interface RS-232
	10	RxD	
	11	RTS/	
	12	CTS/	
	13	GND	
X3	1	TxD-b	Serial COM2 interface RS-422/485
	2	TxD-a	
	3	RxD-b	
	4	RxD-a	
	5	TxD-b'	
	6	TxD-a'	
	7	RxD-b'	
	8	RxD-a'	
	9	TxD	Serial COM2 interface RS-232
	10	RxD	
	11	RTS/	
	12	CTS/	
	13	GND	
X4		USB interface, connection type A	USB0 *
X5	1	VCC	USB1 *
	2	USB -	
	3	USB +	
	4	GND	
X6	1	VCC	USB2 *
	2	USB -	
	3	USB +	
	4	GND	
	5	GND	
X7	1	VCC	USB3 *
	2	USB -	
	3	USB +	
	4	GND	

X8	0	+U_INT1	Reader interface
	1	0V	
	2	+U_EX1	
	3	GND	
	4	+U_RD	
	5	Signal 1	
	6	Signal 2	
	7	Signal 3	
	8	Signal 4	
	9	+U_EX1 (out)	
X9	1	VCC	PS2 interface ** for External keyboard / Mouse
	2	KBDAT	
	3	KBCLK	
	4	MSDAT	
	5	MSCLK	
	6	GND	
X10	1	Optical fiber connection type SC	Ethernet optical fiber interface ***
X11	1	TxD (+)	Ethernet copper Connection ***
	2	TxD (-)	
	3	RxD (+)	
	4	RxD (-)	

- ☞ \* USB connections USB0 and USB2 as well as USB1 and USB3 are wired in parallel. The USB connections USB0 and USB2 as well as USB1 and USB3 must therefore **NOT** be used **AT THE SAME TIME** !
- ☞ Please also note that the COM interfaces may only be physically connected once ! The interconnection is either with a physical RS-232 or an RS-422/485 connection.
- ☞ \*\* Do **NOT** connect the optional external keyboard to live equipment !
- ☞ \*\* Please note that the Ethernet interface is designed **either** as an optical fiber version (X10) **or** a copper version (X11), depending on the version ordered !  
For the optical fiber connection you have to use an optical fiber cable with 62.5 µm core diameter and 125 µm outer diameter.  
Cables connected to the Ethernet terminals (X11) must have a minimum cross section of 0.2 mm<sup>2</sup> (metrically) (AWG 24).  
Which cable cross sections are chosen should be decided on the basis of relevant regulations, such as DIN VDE 0298. Factors that might require a larger cross section, such as current, increased temperatures, cable bundling, etc. must also be taken into account !

**13.2.1 Dip switch settings S3 and S4**

Switch	Position	Interface	Function	
S3-1	OFF	COM1 RS-422/485	No bus terminator resistor set	
	ON		Bus terminator resistor TxD line	
S3-2	OFF		COM2 RS-422/485	No bus terminator resistor set
	ON			Bus terminator resistor RxD line
S4-1	OFF	COM1 RS-422/485		No bus terminator resistor set
	ON			Bus terminator resistor TxD line
S4-2	OFF		COM2 RS-422/485	No bus terminator resistor set
	ON			Bus terminator resistor RxD line

### 13.3 Connections Ex-e terminals (X12)

Up to 8 Ex-e terminal blocks may be mounted inside the connection box of the housing (**NOT** NEC). Because these terminal blocks are exclusively mounted during production, this option must be specified when ordering the product.

For devices with these optional terminal blocks, please note the following:

- Either Ex-e, Ex-nL or I.S. circuits may be connected to these terminal blocks !



Ex-e, Ex-nL or I.S. circuits **MUST NOT** be connected at the same time on terminal block X12.



When connecting cables please ensure that the cable isolation goes right up to the terminal part.

#### 13.3.1 Labelling I.S. circuits

If intrinsically safe circuits are connected at terminal bar X12, all of these terminals and circuits must be marked uniquely and clearly visible, according to EN 60079-11. If a color is used for the marking, this has to be light blue.

#### 13.3.2 Connection details of the I.S. or Ex-nL terminals

Intrinsically safe (I.S.) or energy-limited (Ex-nL) circuits with the following safe maximum values may be connected to terminal block X12:

$$U = 30 \text{ V}$$

$$I = 5 \text{ A}$$

#### 13.3.3 Connection details of the Ex-e terminals

For the alternatively permitted connection of Ex-e circuits the following maximum values apply:

- Maximum nominal voltage:
  - if the fixed bridge bar is not used 275 V
  - if the fixed bridge bar is used 175 V
- Rated current: 4 A
- Maximum rated current: 5 A

#### 13.3.4 Cable types and cross sections

Copper cables with the following cross sections may be used:

- Maximum cable cross section in mm<sup>2</sup> (AWG) 4 (12)
- Minimum cable cross section in mm<sup>2</sup> (AWG) 0,2 (24)

Multiple cable connection to the screw terminal (2 cables of the same cross section and cable type):

- flexible mm<sup>2</sup> (AWG) 0,2 – 1,5 (24 – 16)
- rigid mm<sup>2</sup> (AWG) 0,2 – 1,5 (24 – 16)

Which cable cross sections are chosen should be decided on the basis of relevant regulations, such as DIN VDE 0298. Factors that might require a larger cross section, such as current, increased temperatures, cable bundling, etc. must also be taken into account !

## 14 Maintenance, service

Associated equipment is subject to maintenance, service and testing according to guidelines 1999/92/EC, IEC 60079-19, EN 60079-17 and BetrSichVer !

Because the transmission of the devices remains reliable and stable over long periods of time, regular adjustments are not required.

The following general principles apply for repairs \*, purchase of spare parts \* or exchange of parts \*, where these may be carried out by the user:

- Only original parts provided by the manufacturer must be used.
- Fuses may only be replaced by equivalent fuse types.



\* Please also note [Section 15 Troubleshooting](#) !

If Eagle devices are in storage for longer than six months they should be operated for at least an hour at room temperature (20°C ± 5°C) every six months.

System maintenance should focus on the following:

- a. Seal wear
- b. Screen damage
- c. All screws are tightened fast
- d. All cables and lines are properly connected and undamaged

### 14.1 Servicing

In accordance with IEC 60079-19 and EN 60079-17, operators of electric plants in hazardous areas are obliged to have them serviced by qualified electricians.

### 14.2 Data storage

The Eagle series operator interfaces have no batteries and are thus maintenance-free during their entire life cycle.

Online data is stored on the internal flash memory card and are available even after the device has been switched off for a long time.

Today's flash memory cards can retain data for up to ten years.

### 14.3 Time function

A capacitor ensures the continuation of the time function while the Eagle operator interfaces are switched off. The capacitor can keep up the time function for about five days while the device is switched off. If the device is switched back on later than after an interval of five days, the time has to be reset manually or via another, connected system.

## 15 Troubleshooting

Devices operated in hazardous areas must not be modified. Repairs may only be carried out by qualified, authorized staff specially trained for this purpose.



Repairs may only be carried out by specially trained staff who are familiar with all basic conditions of the applicable user regulations and have been authorized by the manufacturer.

## 16 Disposal

Disposal of packaging and used parts is subject to regulations valid in whichever country the device has been installed.

The disposal of devices sold after August 13th, 2005, and installed in countries under the jurisdiction of the EU is governed by directive 2002/96/EC on waste electrical and electronic equipment (WEEE). Under this directive, operator interfaces are listed in category 9 (monitoring and control instruments).

We shall take back our devices according to our General Terms and Conditions.

### 16.1.1 ROHS directive 2002/95/EC

The prohibition of hazardous substances as detailed in directive 2002/95/EC (ROHS) does not apply to electronic equipment of categories 8 and 9, and is therefore not applicable to the equipment described in these operating instructions.

### 16.1.2 China ROHS labeling

According to new Chinese legislation in force since 01.03.2007, all devices containing hazardous substances must be labeled accordingly.

For our operator interfaces, the following conditions apply:

#### Names and contents of toxic or hazardous substances or elements:

Part Name	Toxic or hazardous substances and elements					
	Lead (Pb)	Mercury (Hg)	Cadmium (Cd)	Hexa- valent Chromium (Cr (VI))	Poly- brominated Biphenyls (PBB)	Poly- brominated diphenyl ethers (PBDE)
Housing	○	○	○	○	○	○
Display	○	○	○	○	○	○
all PCBs	X	○	○	○	○	○
Miscellaneous	○	○	○	○	○	○

○ Indicates that this toxic or hazardous substance contained in all of the homogeneous materials for this part is below the limit requirements in SJ/T11363-2006.

X Indicates that this toxic or hazardous substance contained in at least one of the homogeneous materials for this part is below the limit requirements in SJ/T11363-2006.

## 17 Front panel resistance

This section contains information on the resistance of the operator interfaces to various environmental factors. These have an impact on the mechanical, thermal and chemical stability of the operator interfaces.

The resistance to chemicals was tested according to DIN 42115 Part 2, i.e. the stability over 24 hours without visible changes to the operator interfaces.

### 17.1 Design

Structure:

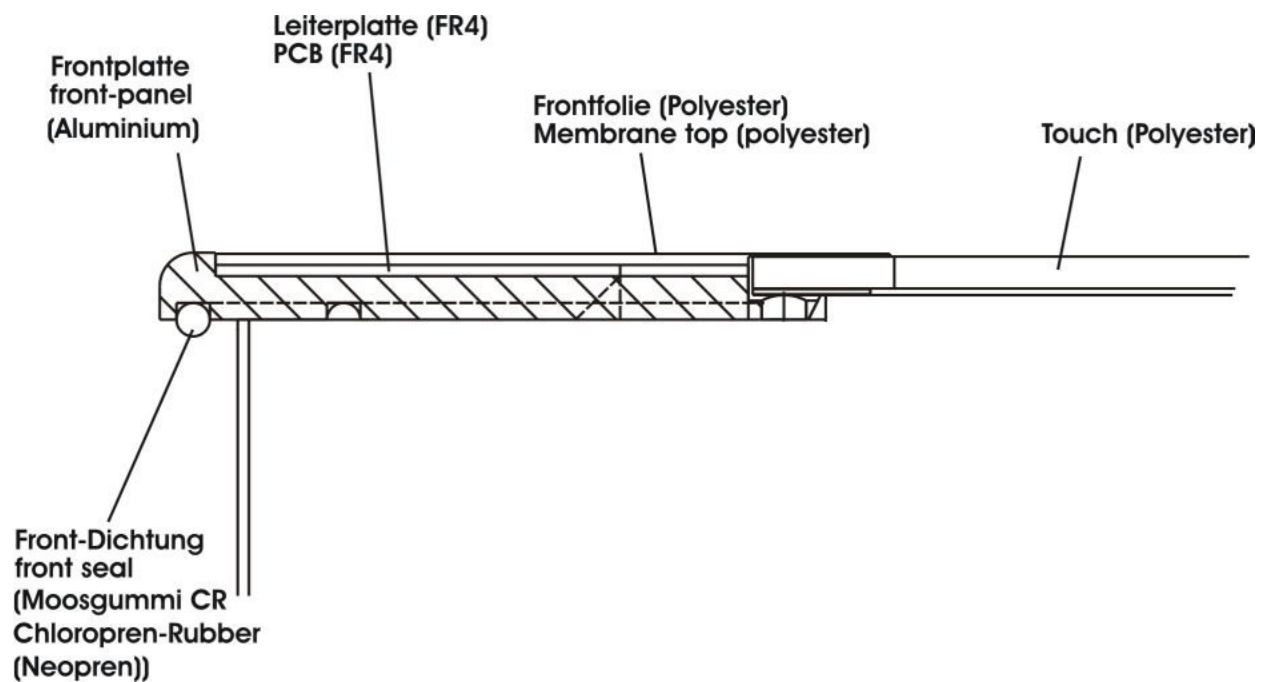
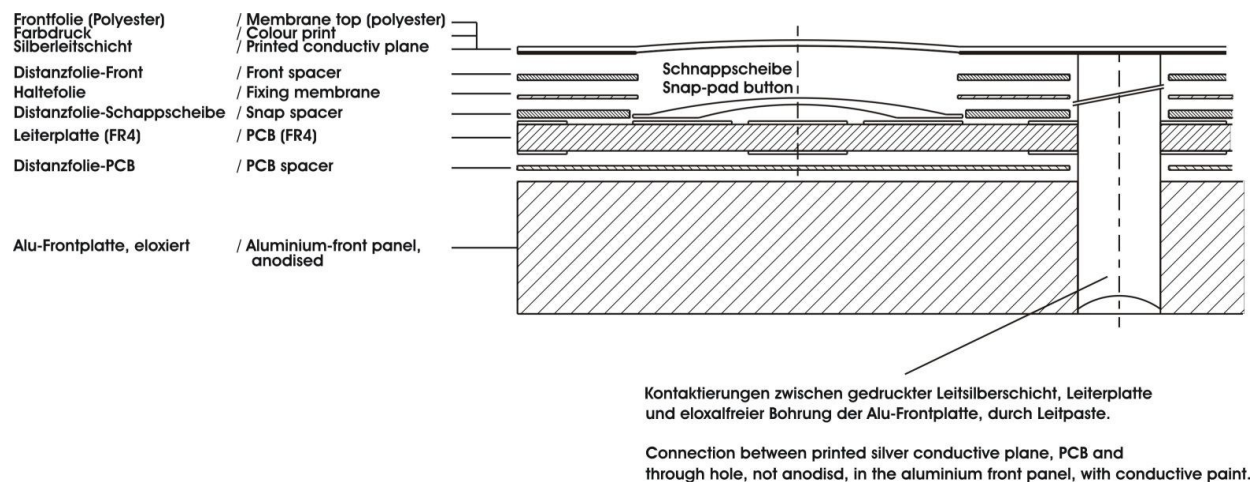

Diagram:





## 17.2 Materials

Application	Material
Membrane top	Polyester
Touch screen	Polyester / safety glass
PCB	FR4
Front plate	Aluminum
Housing	Stainless steel
Front panel seal	Chloropren-Rubber (Neopren)

## 17.3 Material properties

- ☞ The selection of chemicals listed here is not exhaustive.
- ☞ More comprehensive lists can be obtained for further information from R. STAHL HMI Systems GmbH.
- ☞ Because of the numerous chemical substances available on the market, these lists can only represent a selection.
- ☞ Further information can also be found on the following homepage:  
<http://macdermidautotype.com/>

### 17.3.1 Entire device

- ☞ The chemical substances and resistances are the lowest common denominator of all materials used in the operator interface.  
 Thus, the entire device has a somewhat lower chemical resistance than the individual materials.

Property	Chemical material class / group	Chemical substances	Test method
Chemical <ul style="list-style-type: none"> <li>• Chemical resistance</li> </ul>	Alcohols	Ethanol Methanol Glycerin	DIN 42115 DIN 53461
	Amines	Ammonia <2%	
	Ketones	Acetone	
	Diluted acids	Acetic acid <5%	
	Diluted alkaloids (bases)	Caustic soda <2%	
	Household chemicals	Detergents	
Property	Resistance		Test method
Mechanical <ul style="list-style-type: none"> <li>• Service life after imprint</li> <li>• MIT folding resistance</li> </ul>	5 million touches >20000 folding operations		Autotype method ASTM D2176
Thermal <ul style="list-style-type: none"> <li>• Dimensional</li> <li>• Dimension stability</li> </ul>	Max. 0.2% at 120° longitudinal Typically 0.1%		Autotype method

- ☞ Polyester films have a limited resistance against UV light and should therefore not be exposed to sunlight for longer periods.

## 17.3.2 Membrane top

Property	Chemical material class / group	Chemical substances	Test method
Chemical • Chemical resistance	Alcohols	1,3 Butanediol 1,4 Butanediol Cyclohexanol Diacetone alcohol Ethanol Glycol Glycerol Isopropyl alcohol Methanol Neopentyl glycol Octanol 1,2 Propylene glycol Triacetin Dowanol DRM/PM	DIN 42115 DIN 53 461 Oder ASTM-F-1598-95
	Aldehydes	Acetaldehyde Formaldehyde 37-42%	
	Amines	Ammonia < 2%	
	Esters	Amyl acetate Ethylacetate N-Butyl acetate	
	Ethers	1.1.1. Trichloroethane Ether Dioxane Diethyl ether 2-Methyltetrahydrofuran (2-ME-THF)	
	Aliphatic hydrocarbons		
	Aromatic hydrocarbons	Benzene Toluene Xylene Paint thinner (white spirit)	
	Ketones	Acetone Methyl ethyl ketone Cyclohexanone Methyl isobutyl ketone (MIBK) Isophorone	
	Diluted acids	Formic acid <50% Acetic acid < 5% Phosphoric acid <30% Hydrochloric acid <10% Nitric acid <10% Trichloroacetic acid <50% Sulfuric acid <30%	
	Diluted alkaloids (bases)	Caustic soda <40%	

Household chemicals	Ajax Ariel Domestos Downey Fantastic Formula 409 Gumption Jet Dry Lenor Persil Tenside Top Jop Vim Vortex Washing powder Fabric conditioner Whis Windex
Oils	Petrol Drilling muds Braking fluid Decon foam Diesel oil Varnish Keroflux Paraffin oil Castor oil Silicone oil Solvent naphta Mineral turpentine Kerosene
No specific material class	Acetonitrile Alkali carbonate Dichromates Potassium dichromate Caustic soda <20% Dibutyl phthalate Dioctyl phthalate Iron II chloride (FeCl <sub>2</sub> ) Iron III chloride (FeCl <sub>3</sub> ) Haloalkanes Potassium soap Potassium hydroxide <30% Sodium bisulfate Tetrachloroethylene Salt water Trichloroethylene Water Hydrogen peroxide <25%

Property	Resistance	Test method
Mechanic (keyboard) <ul style="list-style-type: none"> <li>• Service life after imprint</li> <li>• MIT folding resistance</li> </ul>	5 million touches >20000 folding operations	Autotype method ASTM D2176
Mechanic (touch screen) <ul style="list-style-type: none"> <li>• point activation</li> </ul>	1 million activations at any single point	3M method
Thermal <ul style="list-style-type: none"> <li>• Dimensional</li> <li>• Dimension stability</li> </ul>	Max. 0.2% at 120° longitudinal Typically 0.1%	Autotype method

☞ Polyester films have a limited resistance against UV light and should therefore not be exposed to sunlight for longer periods.

### 17.3.3 Display / Touch screen

Polyester:

Property	Chemical material class / group	Chemical substances	Test method
Chemical <ul style="list-style-type: none"> <li>• Chemical resistance</li> </ul>	(see front membrane)	(see front membrane)	(see front membrane)
Property	Resistance		Test method
Mechanical <ul style="list-style-type: none"> <li>• Service life after imprint</li> <li>• MIT folding resistance</li> </ul>	(see front membrane)		(see front membrane)
Thermal <ul style="list-style-type: none"> <li>• Dimensional</li> <li>• Dimension stability</li> </ul>	(see front membrane)		(see front membrane)

### 17.3.4 Front panel seal

Property	Chemical material class / group	Chemical substances	Test method
Chemical <ul style="list-style-type: none"> <li>• Chemical resistance</li> </ul>	Alcohols	Methanol Glycerol	DIN 53461
	Amines	Ammonia	
	Ketones	Acetone	
	Diluted acids	Formic acid Acetic acid Hydrochloric acid Nitric acid <10%	
	Diluted alkaloids (bases)	Sodium hydroxide	
	Household chemicals	Detergents	
Property	Resistance		Test method
Mechanical	(No information available at present)		
Thermal <ul style="list-style-type: none"> <li>• Installation area</li> </ul>	-30 to 100°C		DIN 53461

## 18 UL Certification

### 18.1 General information

Only Eagle devices with the UL certification may be installed and operated in countries covered by the NEC.

☞ Operator interfaces for installation in countries covered by the NEC have separate ordering numbers (see type code). Please state these when ordering.

⚠ In areas covered by ATEX, an operator interface with UL certification may **ONLY** be installed and operated if the two Conduit Hub connections have been replaced by conventional cable glands !  
To this end, the delivery of operator interfaces with UL certification includes two cable glands.

The Eagle devices with the UL certification may be installed in the following hazardous areas:

- Class I, Division 2, Groups A, B, C, D
- Class II, Division 2, Groups F and G
- Class III, hazardous locations
- Class I, Zone 2, Group IIC
- Temperature classification T4, enclosure type 1

as defined by the NEC, or in non-hazardous areas.

☞ Before installation and operation of the Eagles users **MUST** refer to Control Drawing No. 2010 11 7000 0 !

### 18.2 Safety Advice

Before switching on the Eagle devices and associated equipment, its external equipotential bonding terminal must be properly connected to the equipotential bonding system at its place of installation.

As an alternative, you may connect devices to the Eagles that have been safely disconnected from the earth potential.

#### 18.2.1 Caution

⚠ Non-observance of this safety advice may lead to an explosion !

- The substitution of any component of the Eagle devices may affect safety in hazardous areas and is therefore **NOT** permitted.
- Connected equipment must **NOT** be disconnected from the operator interface when still live, except if the environment is known to be free of ignitable concentrations.

## 18.3 Permitted maximum values

### 18.3.1 Electrical

Power supply (X1):

Vnominal	=	24.0 VDC (min. 20.4 VDC; max. 28.8 VDC)
Vmax	=	30 VDC
I <sub>max</sub>	=	1.9 A

Interfaces RS-232, RS-422 and RS-485 (X2, X3):

RS-422, RS-485:	V <sub>nom</sub> = 5 VDC, V <sub>max</sub> = 253 VAC
RS-232:	V <sub>nom</sub> = ±12 VDC, V <sub>max</sub> = 253 VAC

Memory Stick USBi Drive (X4), USB interface (X6)

Entity parameters for nonincendive field wiring:

V <sub>oc</sub>	=	5.9 V			
I <sub>sc</sub>	=	1.02 A			
P <sub>o</sub>	=	6.02 W			
C <sub>a</sub>	=	8 μF	13 μF	30 μF	43 μF
L <sub>a</sub>	=	10 μH	5 μH	2 μH	1 μH

The capacitances (C<sub>a</sub>) and inductances (L<sub>a</sub>) that are right underneath each other are associated pairs.

USB interfaces (X5, X7):

V <sub>nom</sub>	=	5 VDC
V <sub>max</sub>	=	253 VAC

PS2 interface (X9):

Entity parameters for nonincendive field wiring:

V <sub>oc</sub>	=	5.9 V			
I <sub>sc</sub>	=	200 mA			
P <sub>o</sub>	=	1.18 W			
C <sub>a</sub>	=	19 μF	29 μF		
L <sub>a</sub>	=	2 μH	1 μH		

The capacitances (C<sub>a</sub>) and inductances (L<sub>a</sub>) that are right underneath each other are associated pairs.

LAN optical fibre (X10):

Wavelength	=	1350 nm
Radiant power	≤	35 mW

LAN copper cable (X11):

V <sub>nom</sub>	=	5 VDC
P <sub>nom</sub>	=	100 mW

### 18.3.2 Temperature range

-20°C up to + 55°C

### 18.4 Device with UL certification

Back view:

Example for placement of cable glands in accordance to UL:

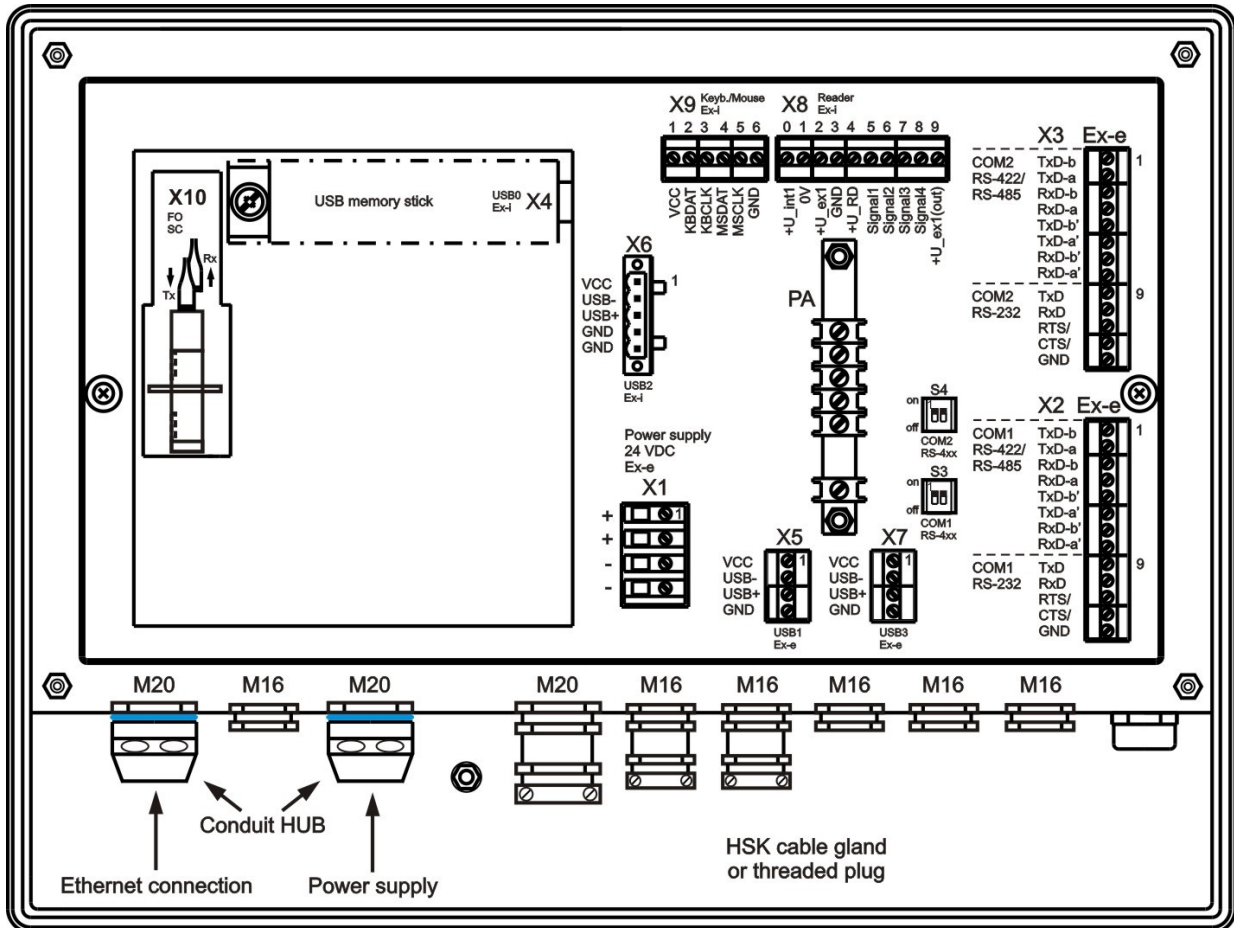

Any cable glands at the operator interface that are not required **MUST BE** replaced by threaded plugs so that the opening in the housing is covered.

☞ Please only use the cable glands for the cables indicated in the CONTROL DRAWINGS !

# 18.5 Control Drawings

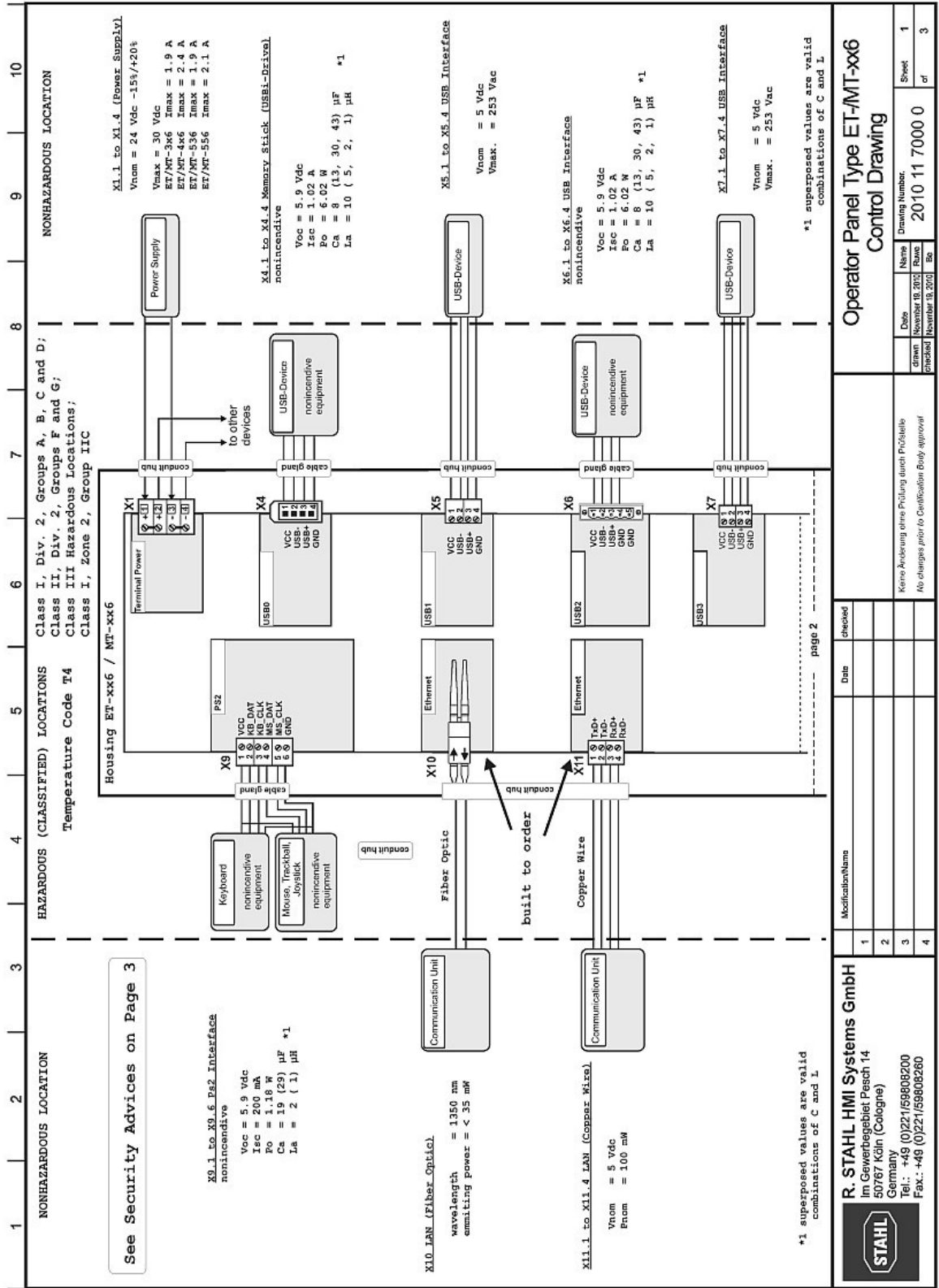

Modification/Name		Date	checked
1			
2			
3			
4			

<b>R. STAHL HMI Systems GmbH</b>			
Im Gewerbegebiet Pesch 14			
50767 Köln (Cologne)			
Germany			
Tel.: +49 (0)221/59808200			
Fax.: +49 (0)221/59808260			

<b>Operator Panel Type EI/MT-xx6</b>			
<b>Control Drawing</b>			
Client	Name	Drawing Number	Sheet
November 18, 2010		2010 11 7000 0	1
checked	November 18, 2010	En	of 3

Aus Rechte vorbehalten! Diese Zeichnung darf ohne unsere ausdrückliche Zustimmung weder vervielfältigt, noch Dritte zugänglich gemacht werden. Außerdem darf sie durch den Empfänger oder durch Dritte nicht in anderer Art und Weise missbräuchlich verwendet werden.



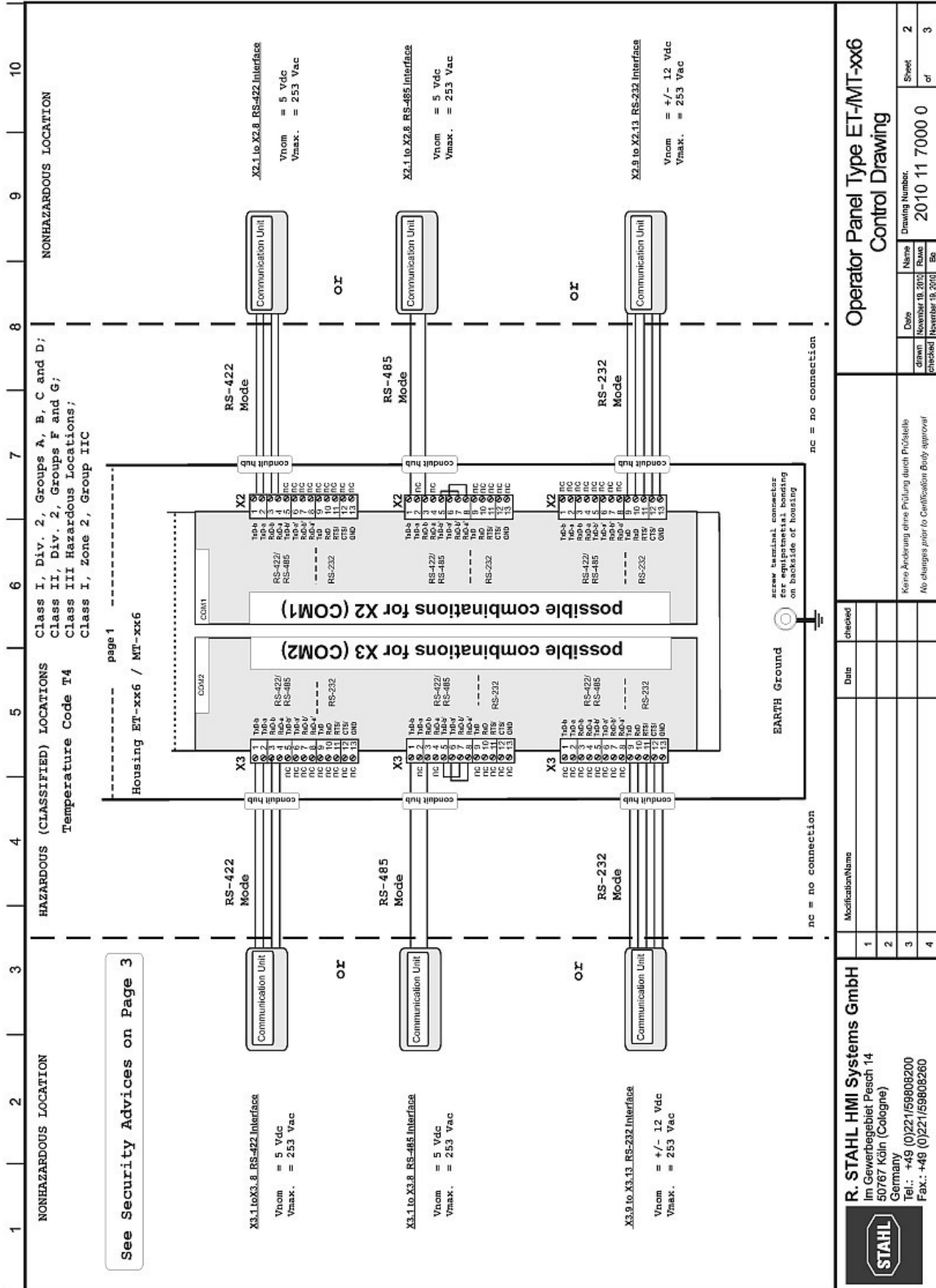

1	2	3	4	5	6	7	8	9	10																																																		
<b>Security Advices</b>																																																											
<p>1. No revision to drawing prior to certification body.</p> <p>2. The Associated Apparatus must be UL Approved.</p> <p>3. Manufacturer's installation drawing must be followed when installing associated apparatus.</p> <p>4. Interconnection of nonincendive equipment apparatus with associated apparatus is allowed when the following is true:</p> <table style="margin-left: 40px; border: none;"> <tr> <td style="padding-right: 20px;">nonincendive Equipment</td> <td style="padding-right: 20px;">Associated Apparatus</td> </tr> <tr> <td>Vmax ≥</td> <td>Voc or Uo</td> </tr> <tr> <td>Imax ≥</td> <td>Isc or Io</td> </tr> <tr> <td>PI ≥</td> <td>PO</td> </tr> <tr> <td>Ca + Ccable ≤</td> <td>Ca (or Co)</td> </tr> <tr> <td>La + Lcable ≤</td> <td>La (or Lo)</td> </tr> </table>										nonincendive Equipment	Associated Apparatus	Vmax ≥	Voc or Uo	Imax ≥	Isc or Io	PI ≥	PO	Ca + Ccable ≤	Ca (or Co)	La + Lcable ≤	La (or Lo)																																						
nonincendive Equipment	Associated Apparatus																																																										
Vmax ≥	Voc or Uo																																																										
Imax ≥	Isc or Io																																																										
PI ≥	PO																																																										
Ca + Ccable ≤	Ca (or Co)																																																										
La + Lcable ≤	La (or Lo)																																																										
<b>Calculation of cable length</b>																																																											
<p>1.) Determination of Ccablemax and Lcabelmax: Ccablemax = Co - Ci (ass. Ap.)</p> <p>Determination of Lcablemax Lcablemax = Lo - Li (ass. Ap.)</p> <p>2.) Determination of cable length C and length L: Length C = Ccablemax Ccable (*1)</p> <p>Length L = Lcablemax Lcable (*1)</p> <p>3.) Determination of absolute cablelength: length C or length L, whatever is less.</p> <p>(*1) when cable parameters are unknown, the following values may be used:</p> <p>Cable = 60 pF/ft. (200 pF/m) Lcable = 0.2 pH/ft. (0.66 pH/m)</p>																																																											
<p><b>WARNING:</b></p> <ul style="list-style-type: none"> <li>- Substitution of components may impair Safety.</li> <li>- To prevent ignition of flammable or combustible atmospheres disconnect power and wait a minimum of 60s before servicing.</li> </ul> <p>The ET-/MT-xx6 operator interfaces and connected devices must be integrated in the same system of potential equalization. As an alternative to this, only devices hat are isolated from earth potential may be connected.</p> <p>All circuits must be wired using</p> <ul style="list-style-type: none"> <li>- Class I, Div. 2 methods as specified in Article 503.10(B);</li> <li>- Class II, Div. 2 methods as specified in Article 502.10(B);</li> <li>- Class III, Div. 1 methods as specified in Article 503.10(A);</li> <li>- Class III, Div. 2 methods as specified in Article 503.10(B) with ref. to Article 503.10(A);</li> </ul> <p>of the National Electric Code NFPA 70 for installation within the United States</p>																																																											
<b>Operator Panel Type ET-/MT-xx6 Control Drawing</b>																																																											
<table border="1" style="width: 100%; border-collapse: collapse;"> <tr> <td style="width: 10%; text-align: center;">Date</td> <td style="width: 10%; text-align: center;">checked</td> <td colspan="8"></td> </tr> <tr> <td style="width: 10%; text-align: center;">1</td> <td style="width: 10%; text-align: center;">1</td> <td colspan="8" style="text-align: center;">Modification/Name</td> </tr> <tr> <td style="width: 10%; text-align: center;">2</td> <td style="width: 10%; text-align: center;">2</td> <td colspan="8"></td> </tr> <tr> <td style="width: 10%; text-align: center;">3</td> <td style="width: 10%; text-align: center;">3</td> <td colspan="8"></td> </tr> <tr> <td style="width: 10%; text-align: center;">4</td> <td style="width: 10%; text-align: center;">4</td> <td colspan="8"></td> </tr> </table>										Date	checked									1	1	Modification/Name								2	2									3	3									4	4								
Date	checked																																																										
1	1	Modification/Name																																																									
2	2																																																										
3	3																																																										
4	4																																																										
<p>R. STAHL HMI Systems GmbH          Im Gewerbegebiet Pesch 14          50767 Köln (Cologne)          Germany          Tel.: +49 (0)221/59808200          Fax.: +49 (0)221/59808260</p>																																																											
<p>Alle Rechte vorbehalten! Diese Zeichnung darf ohne unsere ausdrückliche Zustimmung weder vervielfältigt, noch Dritten zugänglich gemacht werden. Außerdem darf sie durch den Empfänger oder durch Dritte nicht in anderer Art und Weise missbräuchlich verwendet werden.</p>																																																											
<table border="1" style="width: 100%; border-collapse: collapse;"> <tr> <td style="width: 10%; text-align: center;">Date</td> <td style="width: 10%; text-align: center;">Name</td> <td style="width: 10%; text-align: center;">Drawing Number</td> <td style="width: 10%; text-align: center;">Sheet</td> </tr> <tr> <td style="width: 10%; text-align: center;">November 19, 2010</td> <td style="width: 10%; text-align: center;">Bö</td> <td style="width: 10%; text-align: center;">2010 11 7000 0</td> <td style="width: 10%; text-align: center;">3</td> </tr> <tr> <td style="width: 10%; text-align: center;">checked</td> <td style="width: 10%; text-align: center;">checked</td> <td style="width: 10%; text-align: center;">of</td> <td style="width: 10%; text-align: center;">3</td> </tr> </table>										Date	Name	Drawing Number	Sheet	November 19, 2010	Bö	2010 11 7000 0	3	checked	checked	of	3																																						
Date	Name	Drawing Number	Sheet																																																								
November 19, 2010	Bö	2010 11 7000 0	3																																																								
checked	checked	of	3																																																								

## 19 Accessories

### 19.1 Phoenix Contact terminal block

#### 19.1.1 Data sheet Mini-Ex-terminal

Please note that when connected to the operator interfaces the connection values for the explosion proof terminals are limited (see also [chapter "Ex-e terminals"](#)) !



#### Mini-Terminal Block MBK

<b>Article description</b>	MBK 3/E-Z *
Article no.	1413036 *
<b>EC-TYPE EXAMINATION CERTIFICATE IECEX-CERTIFICATE</b>	<b>KEMA 01ATEX2134 U *</b> <b>IECEX KEM 07.0008 U</b>
Marking	Ex e II KEMA 01ATEX2134 U IECEX KEM 07.0008 U
Assembly on mounting rails	NS 15 acc. to EN 60715-TH 15
Stripping length	8 mm
Torque	0,6 - 0,8 Nm
Assembly instructions	See page 2
Operating temperature range	-50 °C ... +110 °C



#### Technical data according to EN 60079-7 (increased safety „e“)

Rated insulation voltage	250 V
Rated voltage	275 V
Nominal current	22,5 A
Max. rated current	28 A

#### Connection capacity

Rated cross-section	2,5 mm <sup>2</sup>	AWG 14
Max. conductor cross-section	4 mm <sup>2</sup>	AWG 12
Connectable conductor cross-section	0,2 - 4 mm <sup>2</sup> rigid	AWG 24 - 12
	0,2 - 2,5 mm <sup>2</sup> flexible	AWG 24 - 14

#### Multi-conductor connection (2 conductors of the same cross-section)

rigid / flexible	0,2 - 4 mm <sup>2</sup> rigid	AWG 24 - 12
	0,2 - 2,5 mm <sup>2</sup> flexible	AWG 24 - 14

#### Data of insulation material

Description	PA 6.6
Creep resistance acc. to IEC 60112 / material group	CTI 600 / I

#### Accessories

	Description	Article no.	
Cover	D-MBK/E	1415021	
Fixed bridge bar	FBRI 10-5 N	2770642	22,0 A / 2,5 mm <sup>2</sup> 22,5 A / 4 mm <sup>2</sup>

\* valid for colour variants

**Important assembly instructions – increased safety „e“**

The Terminal Blocks are suitable for use in enclosures in atmospheres with flammable gases or combustible dust. For flammable gases these enclosures must satisfy the requirements according to EN 60079-0 and EN 60079-7. For combustible dust these enclosures must satisfy the requirements according to EN 50281-1-1.

When assembling with other certified series and sizes of terminal blocks and using belonging accessories, the required creepage distances and clearances have to be observed.

When using the fixed bridge bars to achieve a skipped bridging the rated voltage is reduced to 176 V.

If conductors with smaller cross section as the rated cross section are used, the belonging lower current has to be laid down in the EC-Type Examination Certificate of the complete apparatus.

The Terminal Blocks may be used, based on the self-heating when used at the nominal current and at ambient temperatures of -50 °C to +40 °C at the mounting position in electrical apparatus, e.g. junction and connection boxes, for temperature class T6. When the Terminal Blocks are used in electrical apparatus of temperature classes T1 up to T5, the highest temperature of the insulating material shall not exceed the maximum value of the operating temperature range.

The Terminal Blocks and their appropriate accessories have to be assembled as specified below.

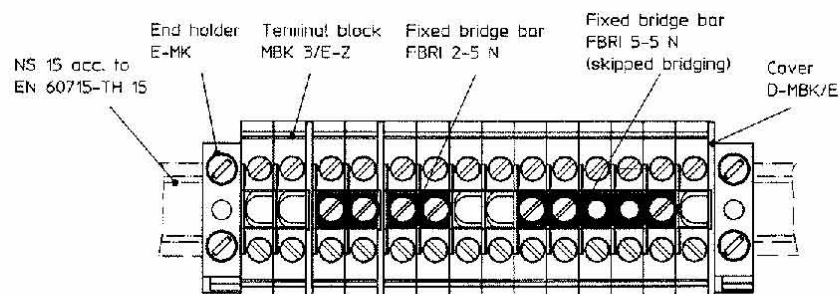

**Operational instructions – Intrinsic safety “i”**

EN 60079-14 Clause 12 describes modular terminal blocks as simple apparatus when used in intrinsically-safe circuits. Testing by a notified body and marking is not required. If terminal blocks be identifiable as part of an intrinsically circuit are marked by a colour, the colour used shall be light blue.

Testing for compliance to intrinsically safe requirements including clearance, creepage, and solid insulation distances specified in EN 60079-0 (EN 50014) and EN 60079-11 (EN 50020) have been performed for circuits up to 60 V.

Compliance with distance requirements of EN 60079-14 Clause 12.2.3 for the connection of separated intrinsically-safe circuit accessories is met. A minimum distance of 50 mm to separate clamping units of intrinsically-safe and non intrinsically-safe circuits is required through the use of a separating plate or similar device.

**Attestation of Conformity**

The above mentioned product is in line with the provisions of the below marked directive and their modification directive(s):

94/9/EC ATEX Directive

Compliance with Essential Health and Safety Requirements has been assured by compliance with:

EN 60079-0:2004 EN 60079-7:2003 EN 50281-1-1:1998 + A1

The conformity with the provisions of the ATEX directive were certified by

Notified Body: KEMA Quality B.V.  
 Address: Utrechtseweg 310, NL-6812 AR Arnhem, The Netherlands [Ident.-No.: 0344]  
 Certificate: KEMA 01ATEX2134 U, 2006-05-15  
 (No., Date)



Blomberg, 2007-12-05

  
 I. A. Gerhard Leßmann  
 Business Unit Device Connection  
 Technology  
 Ex-Representative

  
 Dirk Görlitzer  
 Business Unit Industrial Connection  
 Technology  
 Head of Business Unit

This attestation certifies the conformity with the indicated directive, it does not, however, covenant any characteristics. The instructions for safety and installation have to be observed.

Phoenix Contact GmbH & Co. KG  
 Flachmarktstraße 8  
 32825 Blomberg  
 Germany

 +49 -- (0) 52 35 – 3-00  
 +49 – (0) 52 35 – 3-4 12 00  
 www.phoenixcontact.com

## 20 Declaration of EC conformity

**EG - Konformitätserklärung**  
*EC-Declaration of Conformity*  
 CE-Déclaration de Conformité



Wir / We / Nous

**R. STAHL HMI Systems GmbH**  
 Im Gewerbegebiet Pesch 14  
 D-50767 Köln

**erklären in alleiniger Verantwortung dass unser(e) Produkt(e):**

*declare under our sole responsibility that the product(s):*

*attestons sous notre responsabilité que le(s) produit(s):*

**ProVicom**

**MT-306-S; MT-316-S; MT-336-S; MT-336-VA;  
 MT-406; MT-416; MT-436 (-VA); MT-456 (-VA);  
 MT-506; MT-516; MT-536 (-VA); MT-556 (-VA)**

**gekennzeichnet:**

*marked:*

*marqué:*



II 3 (3) G Ex d e mb nA nL [nL] [op is] IIC T4

II 3 (2) G Ex d e mb nA nL [ib] [op is] IIC T4

II 3 (2) D Ex tD A22 IP65 [ibD] T90°C

**Übereinstimmend ist (sind) mit der (den) folgenden Norm(en) oder normativen Dokumenten:**

*is (are) in conformity with the following standard(s) or normative documents:*

*est (sont) conforme aux norme(s) ou aux documents normatifs suivants:*

Bestimmung der Richtlinie <i>Terms of the directive</i> Prescription de la directive	Titel und/oder Nr. sowie Ausgabedatum der Norm <i>Title and/or No. and date of issue of the standard</i> Titre et/ou No. ainsi que date d'émission des normes	
<b>2004/108/EG: Elektromagnetische Verträglichkeit</b> <i>2004/108/EC: Electromagnetic compatibility</i> 2004/108/CE: Compatibilité électromagnétique	EN 61000-6-2:2005 EN 61000-6-4:2007	
<b>94/9/EG: Geräte und Schutzsysteme zur bestimmungsgemäßen Verwendung in explosionsgefährdeten Bereichen</b> <i>94/9/EC: Equipment and protective systems intended for use in potentially explosive atmospheres</i> 94/9/CE: Appareils et systèmes de protection destinés à être utilisés en atmosphères explosibles	EN 60079-0:2006 EN 60079-1:2007 EN 60079-7:2007 EN 60079-11:2007 EN 60079-15:2005 EN 60079-18:2004 EN 60079-28:2007	EN 61241-0:2006 EN 61241-1:2004 EN 61241-11:2006
<b>EG-Baumusterprüfbescheinigung Nr., ausgestellt durch benannte Stelle:</b> <i>EC-Type Examination Certificate No., issued by notified body:</i> Attestation d'examen CE de type No. exposé par organisme notifié:	<b>TÜV 07 ATEX 7471 X</b> TÜV Rheinland Industrie Service GmbH TÜV Rheinland Group Am Grauen Stein 51105 Köln/Cologne Deutschland/Germany/Allemagne	

Köln, den 01.04.2010

**Ort und Datum**  
*Place and date*  
 lieu et date

Joachim Düren  
 Technical Director

Werner Bertges  
 Quality Manager

## 21 Release Notes

The chapter entitled "Release Notes" contains all the changes made in every version of the operating instructions.

### Version 02.04.07

- Correction of "equipotential" in section 11.2 "General information"
- Addition section 6 "Product identification"
- Deletion of previous information on the document versions
- Removal of all certificates to make up a separate document
- Inclusion of -40°C in the chapter entitled Technical Data
- Inclusion of Chinese CNEX certificate in chapter 5 "Certificates"
- Inclusion of Kazakh CKT certificate in chapter 5 "Certificates"
- Inclusion of UL certificate in chapter 5 "Certificates"
- Deletion of certificate information from chapter entitled Technical Data
- Addition of installation notes regarding NEC in chapter 11.2 "Installation"
- Inclusion of section 18 "UL certificate"
- Inclusion of note concerning separate documentation with certificates in section "Preface"
- Inclusion of section "Operation in countries covered by NEC" in the chapter "Safety Advice", section "Installation and Operation"
- Re-named chapter "Software Installation", new name: "Installation via USB interfaces"
- Insert "Protect operator interfaces against permanent UV-exposure" into chapter "Installation - "MT-3x6-Tx, MT-3x6-Fx"
- Adapted "Autotype" link
- Removal of ElexV and VDE0100 in chapter "Installation"
- Inclusion of comment "not for NEC" for terminal block
- Stylistic changes
- Addition of installation notes regarding terminal block X12 in chapter "Installation" - "MT-3x6-Tx, MT-3x6-Fx"

### Version 02.04.08

- Addition type code for UL device
- Addition product identification for UL device
- Changing of section "UL certification"
- Changing of "operation UL device in NEC" in section "Installation and operation"
- Removal of "operation UL device in NEC" in section "Installation"

R. STAHL HMI Systems GmbH  
Im Gewerbegebiet Pesch 14  
D-50767 Köln

Phone: (switchboard) +49/(0)221/ 5 98 08 - 200  
(hotline) - 59

Fax: - 260

E-mail: (switchboard) office@stahl-hmi.de  
(hotline) support@stahl-hmi.de

[www.stahl.de](http://www.stahl.de)  
[www.stahl-hmi.de](http://www.stahl-hmi.de)

