



## Schaltschrank Installationsanleitung Cabinet installation guide

## Inhaltsverzeichnis

1	Angaben zu diesem Dokument .....	3
2	Projektierung.....	3
2.1	Projektierung der Schaltschrankentwärmung .....	3
2.2	Standardaufbau mit senkrecht installierter Hutschiene im Schaltschrank .....	5
2.3	Allgemeine Regeln für die Anordnung der Geräte im Schaltschrank.....	7
2.4	Maximal zulässige Umgebungstemperaturen.....	9

## Content

1	Information about this document .....	24
2	Planning.....	24
2.1	Planning of the cabinet power dissipation.....	24
2.2	Standard design based on vertical DIN rail of a control cabinet.....	26
2.3	Best practice for the installation of devices in a control cabinet .....	28
2.4	Max. ambient temperatures.....	30

## 1 Angaben zu diesem Dokument

Dieses Dokument soll Ihnen bei der richtigen Installation der Trennstufenreihe ISpac 91xx helfen. Es gibt Ihnen wichtige Hinweise betreffend des Einbaus im Schaltschrank. Bei diesem Dokument handelt es sich nicht um eine Betriebsanleitung. Bitte lesen sie sorgfältig die dem eingesetzten ISpac Typ entsprechende Betriebsanleitung, bevor sie die Geräte in Betrieb nehmen.

## 2 Projektierung

### 2.1 Projektierung der Schaltschrankentwärmung

Durch den Betrieb der ISpac Trennstufen entsteht eine Verlustleistung in Form von Wärme. Diese Wärme muss durch geeignete Maßnahmen von den ISpac Trennstufen abgeführt werden, da eine überhöhte Umgebungstemperatur zum vorzeitigen Ausfall der Geräte führen kann. Dies kann am besten durch einen Schaltschrank mit Lüftern oder einer Klimaanlage erfolgen. Dieser Aufbau ist der Installation in einem offenen Gestell oder einem Schaltschrank ohne Lüfter überlegen.

Für die Auswahl der Installationsmethode und die Festlegung dieser Maßnahmen schlagen wir folgende Vorgehensweise vor:

1. **Klären sie die Umgebungstemperatur für den Schaltschrank oder das Gehäuse.**
2. **Welche Anforderungen bestehen bezüglich IP-Schutz entsprechend EN 60529?**
3. **Berechnen der maximalen Verlustleistung aller eingebauten/installierten Geräte**  
Dieses Dokument enthält die Angaben zur Verlustleistung für alle ISpac Geräte. Multiplizieren sie diese Angaben mit der Anzahl der Geräte. Addieren sie dazu die Werte von weiteren eingebauten Geräten.
4. **Ermitteln der maximal zulässigen Temperatur im Schaltschrank/Umgebung**  
Dieses Dokument enthält die Angaben zu den maximal zulässigen Umgebungstemperaturen für die ISpac Geräte im Schaltschrank/offenen Gestell. Die maximale Umgebungstemperatur hängt unter anderem von der Einbaulage ab. Bitte beachten sie diesen Umstand beim mechanischen Aufbau des Schrankes.
5. **Auswahl der geeigneten Entwärmungsmethode**

#### a) Geschlossenen Schränken (ohne Öffnungen/Lüfter)

Anwendung	Bei geringer Verlustleistung und wenn das System in einer staubigen oder rauen Umgebung installiert ist, die Temperatur außerhalb des Schaltschranks/Gehäuses muss geringer sein als die Innentemperatur.
Berechnung max. Verlustleistung	$P_{\max} = \Delta T * S * K$ <div style="display: flex; justify-content: space-between;"> <div style="width: 45%;"> <p><math>P_{\max}</math> [W]</p> <p><math>\Delta T</math> [°C]</p> <p><math>S</math> [m<sup>2</sup>]</p> <p><math>K</math> [(W/m<sup>2</sup>*°C)]</p> </div> <div style="width: 50%;"> <p>max. zulässige Verlustleistung im Schaltschrank</p> <p>max. zulässige Temperaturerhöhung</p> <p>freie, wärme-emittierende Oberfläche des Schaltschranks</p> <p>thermischer Leitfähigkeitskoeffizient (lackierter Stahl: <math>K = 5,5</math>, siehe Spezifikation des Schaltschrankherstellers)</p> </div> </div>

Der errechnete Wert  $P_{\max}$  muss kleiner als die Summe der durchschnittlichen Verlustleistungen (70 % der max. Verlustleistung) der eingebauten Geräte sein:  $P_{\max} > \sum P_{70\%}$

Beachten sie bei der Installation im Außenbereich den Einfluss der Sonneneinstrahlung. Die Kombination von hoher Umgebungstemperatur und direkter Sonneneinstrahlung führt oft zu unzulässig hohen Betriebstemperaturen. In diesen Fällen bietet sich der Einsatz eines Sonnenschutzdaches an.

### b) Schränke mit Öffnungen bzw. Gestelle (ohne Lüfter)

Anwendung	Bei geringer Verlustleistung und klimatisierten Räumen, es ist auf ausreichend Abstand zwischen den Geräten zu achten
Berechnung max. Verlustleistung	Siehe Fall a) Je nach Ausführung kann die <b>doppelte</b> zulässige Verlustleistung wie unter a) erreicht werden.

Der errechnete Wert  $P_{\max}$  muss kleiner als die Summe der durchschnittlichen Verlustleistungen (70 % der max. Verlustleistung) der eingebauten Geräte sein:  $P_{\max} > \sum P_{70\%}$

### c) Schränken mit Lüfter und Öffnungen

Anwendung	Bei mittleren bis hohen Verlustleistungen. Ein oder mehrere Lüfter erzeugen einen Luftstrom von der unteren Schranköffnung <u>an den Geräten vorbei</u> durch die obere Schranköffnung hinaus.  Die Umgebungstemperatur des Schaltschranks ist niedriger oder gleich der erforderlichen Betriebstemperatur der eingebauten Geräte.						
Berechnung des notwendigen Luftstroms	Siehe Fall a), im zweiten Schritt ist die Berechnung der Lüfterleistung erforderlich. <b><math>Q = (3,1 * P_{70\%}) / \Delta T</math></b>  <table style="width: 100%; border: none;"> <tr> <td style="width: 50%;"><math>Q</math> [m<sup>3</sup>/h]</td> <td>notwendiger Luftstrom</td> </tr> <tr> <td><math>P_{70\%}</math> [W]</td> <td>entstehende Verlustleistung (70 % der max. Verlustleistung)</td> </tr> <tr> <td><math>\Delta T</math> [°C]</td> <td>zulässige Temperaturerhöhung im Schaltschrank</td> </tr> </table>	$Q$ [m <sup>3</sup> /h]	notwendiger Luftstrom	$P_{70\%}$ [W]	entstehende Verlustleistung (70 % der max. Verlustleistung)	$\Delta T$ [°C]	zulässige Temperaturerhöhung im Schaltschrank
$Q$ [m <sup>3</sup> /h]	notwendiger Luftstrom						
$P_{70\%}$ [W]	entstehende Verlustleistung (70 % der max. Verlustleistung)						
$\Delta T$ [°C]	zulässige Temperaturerhöhung im Schaltschrank						

- Beim Aufstellen des Schaltschranks auf einem Doppelboden, ist der Boden des Schaltschranks gegenüber dem Doppelboden abzudichten.

### d) Klimaanlage

Anwendung	Bei sehr hohen Verlustleistungen und/oder einer Umgebungstemperatur, die über der maximal zulässigen Betriebstemperatur der eingebauten Geräte liegt.
Berechnung	Siehe Fall a), die Leistung des Klimagerätes ist der Gesamtverlustleistung anzupassen.

## 2.2 Standardaufbau mit senkrecht installierter Hutschiene im Schaltschrank

Der nachfolgend beschriebene Aufbau basiert auf einer mehrmonatigen Testreihe, bei der die optimale Luftführung im Schaltschrank ermittelt wurde. Wichtig ist dies speziell für die maximale Lebensdauer der verbauten Komponenten und Auslegung der Umgebungsbedingungen.

Die Basis ist ein Schaltschrank mit den Maßen (H x B x T) von 2000 x 800 x 800 mm. Der Schrank ist mittig durch zwei Montageplatten aufgeteilt.



Bild 1 Standardaufbau mit senkrecht installierter Hutschiene im Schaltschrank



Bild 2 Sicht (Querschnitt) auf die pac-Träger mit Kabelkanal

**Die Besonderheit des Aufbaus:**

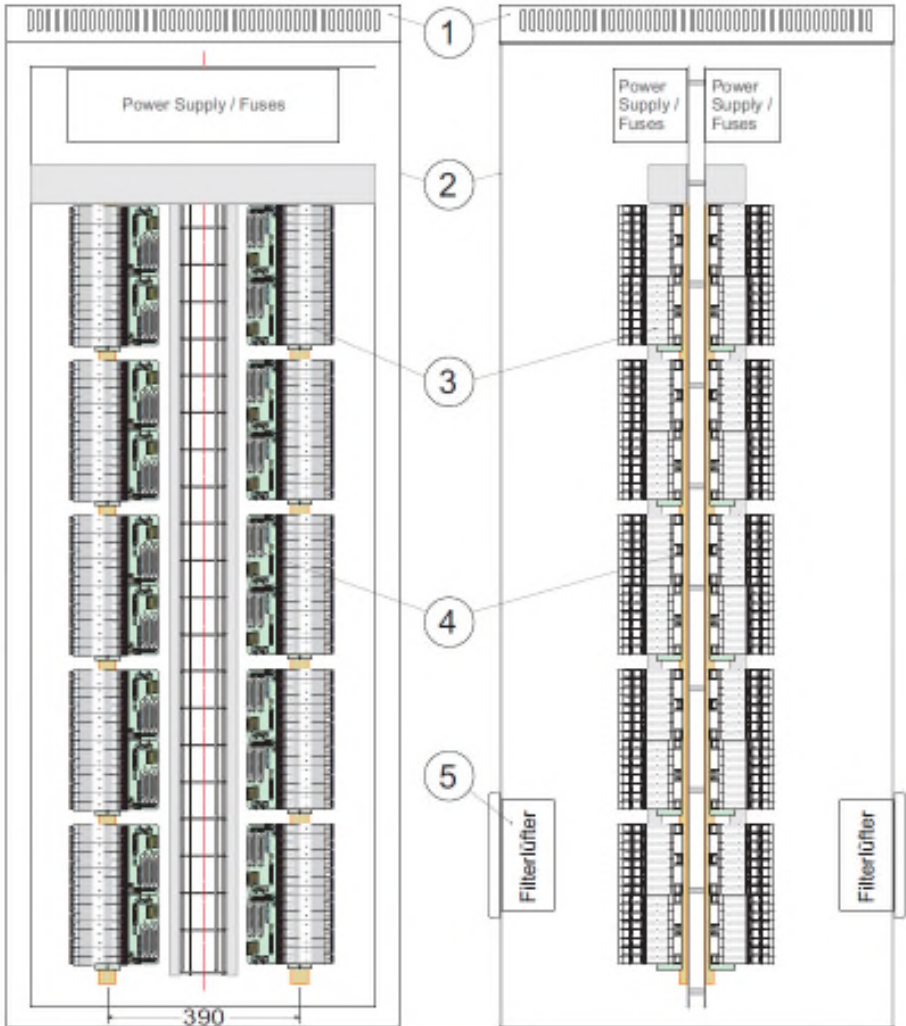
Mit diesem Aufbau kann der Schaltschrank mit bis zu 40 pac-Träger bestückt werden.

#	Bezeichnung	Anzahl	Hersteller	Bestell-Nr.
1	Belüftetes Dachblech	1	Rittal	9659.535
2	Schaltschrank	1	Rittal	8808.750
3	ISpac (ein-/zweikanalige Module)	bis zu 640 Kanäle	R. STAHL	*)
4	pac-Träger			
	mit 8 Slots	bis zu 40	R. STAHL	9195*)
	mit 16 Slots	bis zu 20	R. STAHL	9195*)
5	TopTherm Filterlüfter	2 x 2	Rittal	3240.100

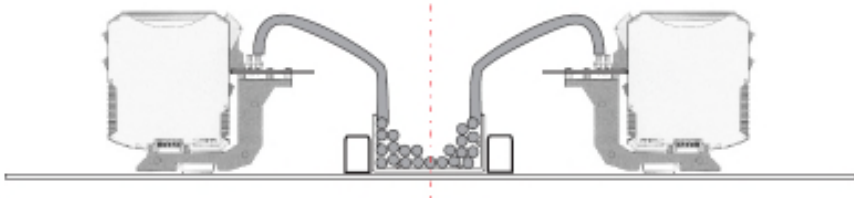
\*) Siehe spezifische Bestell-Nr. im Datenblatt / Engineering Guide

<b>i</b>	<ul style="list-style-type: none"> <li>Nur der Abstandshalter (244971) von Firma R. Stahl darf zwischen den pac-Trägern mit senkrecht installierter Hutschiene im Schaltschrank eingesetzt werden.</li> <li>Verwenden Sie einen Hutschienehalter am Ende der senkrecht installierten Hutschiene, welche das Wegrutschen der pac-Träger auf der Hutschiene verhindert</li> </ul>
----------	---

### 2.3 Allgemeine Regeln für die Anordnung der Geräte im Schaltschrank

Als Ergänzung zu den oben dargestellten empfohlenen Aufbau, müssen folgende Regeln beachtet werden.

1. Beachten Sie, dass die Summe der Verlustleistungen aller eingebauten Geräte kleiner sein muss als die errechnete oder angegebene maximale Verlustleistung des Schaltschranks. Dazu können sie auf Klimaberechnungsprogramme der Schaltschrankhersteller (z.B. Rittal Therm) zurückgreifen.
2. Die ISpac Geräte können in beliebiger Lage eingebaut werden. Der waagrechte Einbau erlaubt jedoch eine bessere Wärmeabfuhr als der senkrechte Aufbau.
3. Platzieren Sie Geräte mit höherer Verlustleistung wie z.B. die Stromversorgungsbaugruppe in den oberen Teil des Schrankes.
4. Sollten Sie die ISpac Geräte oder pac-Träger nicht wie empfohlen aufbauen, ist für ausreichend Platz zwischen ISpac Geräten und Kabelkanälen zu sorgen. Wir empfehlen einen Abstand von mindestens 6 cm (siehe Bilder 2 und 3). Wir empfehlen wir die Hutschiene mit Hilfe von Abstandshalter aus der Ebene der Kabelkanäle herauszuheben und die somit besser dem Luftstrom auszusetzen.
5. Achten Sie bei der Installation darauf, dass die verlegten Systemkabel (zwischen pac-Träger und I/O Karte vom Automatisierungssystem) den Luftaustausch nicht behindern.
6. Vermeiden Sie den Einsatz von Aderbeschriftung, die den Luftaustausch verhindern.
7. Die Filter für die Lufteintritte und Luftaustritte sind entsprechend der Umgebungsbedingungen regelmäßig zu überprüfen und zu wechseln.
8. Achten sie darauf, dass bei einem Schaltschrank mit Lüfter den Boden des Schaltschranks gegenüber dem Doppelboden abzudichten.



Bild 6 Waagrechte Anordnung im Schaltschrank

- 1 Standard Kabelkanal
- 2 Trennstufen ISpac
- 3 Ex i Kabelkanal
- 4 Trennstufen im pac-Träger

Abstand zwischen  
Geräten und Kabelkanal  
von min. 6 cm einhalten

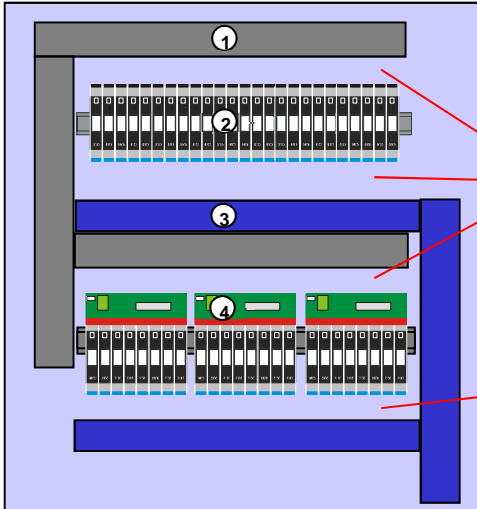

Bild 7 Senkrechte Anordnung im Schaltschrank

- 1 Standard Kabelkanal
- 2 Trennstufen ISpac
- 3 Ex i Kabelkanal
- 4 Trennstufen im pac Träger

Abstand zwischen Geräten  
und Kabelkanal von min.  
6 cm einhalten

Abstand (senkrecht) zwischen  
den pac-Trägern bzw. 16  
Geräten von min.  
3 cm einhalten.

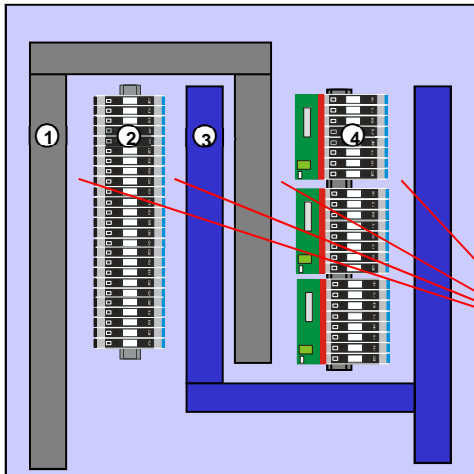

## 2.4 Maximal zulässige Umgebungstemperaturen



Je nach Gerätetyp und Einbaubedingung ergeben sich unterschiedliche, maximal zulässige Umgebungstemperaturen.

Auf den nachfolgenden Seiten finden sie Tabellen, die die maximal zulässigen Umgebungstemperaturen entsprechend dem Gerätetyp angeben.

Bei den angegebenen Grenzwerten handelt es sich um die Temperatur gemessen in einer Entfernung von etwa 2..3 cm zum Gerät. Die Oberfläche des Gerätes kann höhere Werte erreichen. Wir empfehlen diese Grenzwerte durch eine Messung nach Inbetriebnahme zu verifizieren.

### Ex i Stromversorgung Typ 9143





#### Maximale Umgebungstemperatur

	Installation:	Einzelgerät	DIN-Schiene	
	Einbaulage:	beliebig	vertikal	horizontal
Kanäle	Type:			
	Belüftung:	Mit Umluft und CVD (+20% mehr Geräte)		
1	9143/1.-...-...-...	70°C	70°C	--
	Belüftung:	Mit Umluft		
1	9143/1.-...-...-...	70°C	70°C	70°C
	Belüftung:	Ohne Umluft		
1	9143/1.-...-...-...	70°C	70°C	70°C

Hilfsenergie	Typ	max. Verlustleistung (24 V DC) [W]	max. Verlustleistung (115 / 230 V AC) [AV]	70 % Verlustleistung
24 V UC	9143/10-065-200-10s	1,70		1,19
	9143/10-099-220-10s	3,18		2,23
	9143/10-104-220-10s	3,10		2,17
	9143/10-114-200-10s	2,73		1,91
	9143/10-124-150-10s	1,77		1,24
	9143/10-156-160-10s	1,94		1,36
	9143/10-187-050-10s	1,38		0,97
	9143/10-244-060-10s	1,88		1,32
115-230 AC	9143/10-187-050-20s		1,38 / 2,58	0,97 / 1,8
	9143/10-156-160-20s		1,94 / 2,84	1,36 / 1,99
	9143/10-124-150-20s		1,27 / 1,97	0,89 / 1,38
	9143/10-114-200-20s		1,83 / 2,63	1,28 / 1,84
	9143/10-104-220-20s		2,10 / 2,7	1,47 / 1,89
	9143/10-065-200-20s		1,40 / 2,4	0,98 / 1,68
	9143/10-244-060-20s		1,68 / 2,88	1,18 / 2,02

## Frequenzmessumformer Typ 9146

## Maximale Umgebungstemperatur

	Installation:	Einzelgerät	DIN-Schiene		pac-Träger		
	Einbaulage:	beliebig	vertikal	horizontal	vertikal	horizontal	
Kanäle	Type:						
	Belüftung:	Mit Umluft					
1	9146/10-11-12	70°C	65°C	70°C	55°C	60°C	
2	9146/20-11-11	70°C	65°C	70°C	55°C	60°C	
	Belüftung:	Ohne Umluft					
1	9146/10-11-12	70°C	50°C	65°C	40°C	60°C	
2	9146/20-11-11	70°C	50°C	65°C	40°C	60°C	





## Verlustleistung

In den Datenblättern wird die max. Verlustleistung im Nennbetrieb angegeben. Da in der Praxis nicht alle Geräte gleichzeitig unter Vollast betrieben werden, erfolgt die Projektierung üblicherweise mit einer durchschnittlichen Verlustleistung von 70 %. ( $P_{70\%}$ ).

Typ	Kanäle	max. Verlustleistung	70 % Verlustleistung
9146/10-1*-1*	1	1,1 W	0,77 W
9146/20-1*-1*	2	1,5 W	1,05 W

## Vibrationsmessumformer Speisegerät Typ 9147

## Maximale Umgebungstemperatur

	Installation:	Einzelgerät	DIN-Schiene		pac-Träger		
	Einbaulage:	beliebig	vertikal	horizontal	vertikal	horizontal	
Kanäle	Type:						
	Belüftung:	<b>Mit Umluft</b>					
1	<b>9147/10-99-10</b>	70°C	70°C	60°C	50°C	60°C	
2	<b>9147/20-99-10</b>	65°C	65°C	60°C	50°C	55°C	
	Belüftung:	<b>Ohne Umluft</b>					
1	<b>9147/10-99-10</b>	70°C	50°C	55°C	40°C	45°C	
2	<b>9147/20-99-10</b>	65°C	45°C	45°C	30°C	40°C	





## Verlustleistung

In den Datenblättern wird die max. Verlustleistung im Nennbetrieb angegeben. Da in der Praxis nicht alle Geräte gleichzeitig unter Vollast betrieben werden, erfolgt die Projektierung üblicherweise mit einer durchschnittlichen Verlustleistung von 70 %. ( $P_{70\%}$ ).

Typ	Kanäle	max. Verlustleistung	70 % Verlustleistung
9147/10-99-10	1	1,35 W	0,95 W
9147/20-99-10	2	1,7 W	1,2 W

## Messumformerspeisegerät Typ 9160

## Maximale Umgebungstemperatur

	Installation:	Einzelgerät	DIN-Schiene		pac-Träger		
	Einbaulage:	beliebig	vertikal	horizontal	vertikal	horizontal	
Kanäle	Type:						
	Belüftung:	<b>Mit Umluft</b>					
1	9160/13-1-..	70 °C	70 °C	70 °C	60 °C	60 °C	
	9160/19-1-..	70 °C	60 °C	60 °C	50 °C	50 °C	
2	9160/23-1-..	70 °C	60 °C	60 °C	50 °C	50 °C	
	Belüftung:	<b>Ohne Umluft</b>					
1	9160/13-1-..	70 °C	60 °C	65 °C	55 °C	60 °C	
	9160/19-1-..	70 °C	45 °C	50 °C	30 °C	45 °C	
2	9160/23-1-..	70 °C	45 °C	50 °C	30 °C	45 °C	





## Verlustleistung

In den Datenblättern wird die max. Verlustleistung im Nennbetrieb (Ausgang 20 mA; Hilfsenergie 24 V DC; Last = 250 Ω) angegeben. Da in der Praxis nicht alle Geräte gleichzeitig unter Volllast betrieben werden, erfolgt die Projektierung üblicherweise mit einer durchschnittlichen Verlustleistung von 70 %. ( $P_{70\%}$ ).

Typ	Kanäle	max. Verlustleistung	70 % Verlustleistung
9160/13-10-10 9160/1.-11-11	1	1,4 W	1 W
9160/13-11-13	1	1,8 W	1,26 W
9160/2.-11-11 9160/23-10-10	2	2,3 W	1,61 W

## Messumformerspeisegerät mit Grenzwerten Typ 9162

## Maximal zulässige Umgebungstemperaturen

	Installation:	Einzelgerät	DIN-Schiene		pac-Träger	
	Einbaulage:	beliebig	vertikal	horizontal	vertikal	horizontal
Kanäle	Type:					
	Belüftung:	<b>Mit Umluft</b>				
1	9162/13-11-..	70°C	58°C	60°C	52°C	60°C
	Belüftung:	<b>Ohne Umluft</b>				
1	9162/13-11-..	70°C	48°C	56°C	35°C	50°C





## Verlustleistung

In den Datenblättern wird die max. Verlustleistung im Nennbetrieb (Ausgang 20 mA; Hilfsenergie 24 V DC; Last = 250 Ω) angegeben. Da in der Praxis nicht alle Geräte gleichzeitig unter Volllast betrieben werden, erfolgt die Projektierung üblicherweise mit einer durchschnittlichen Verlustleistung von 70 %. ( $P_{70\%}$ ).

Typ	max. Verlustleistung	70 % Verlustleistung
9162/13-11-..	1,5 W	1,05 W

## Trennübertrager HART Eingang Typ 9163

## Maximale Umgebungstemperatur

	Installation:	Einzelgerät	DIN-Schiene		pac-Träger	
	Einbaulage:	beliebig	vertikal	horizontal	vertikal	horizontal
Kanäle	Type:					
	Belüftung:	<b>Mit Umluft</b>				
1	<b>9163/11-81-10</b>	70°C	70°C	70°C	70°C	70°C
2	<b>9163/23-1.-1.</b>	70°C	70°C	70°C	60 °C	70°C
	Belüftung:	<b>Ohne Umluft</b>				
1	<b>9163/11-81-10</b>	70°C	60 °C	70 °C	55 °C	65 °C
2	<b>9163/23-1.-1.</b>	70°C	50 °C	60 °C	45 °C	60 °C





## Verlustleistung

In den Datenblättern wird die max. Verlustleistung im Nennbetrieb (Ausgang 20 mA; Hilfsenergie 24 V DC; Last = 250 Ω) angegeben. Da in der Praxis nicht alle Geräte gleichzeitig unter Vollast betrieben werden, erfolgt die Projektierung üblicherweise mit einer durchschnittlichen Verlustleistung von 70 %. ( $P_{70\%}$ ).

Typ	Kanäle	max. Verlustleistung	70 % Verlustleistung
9163/13-1.-1. 9163/11-81-10	1	0,7 W	0,5 W
9163/23-1.-1.	2	2 W	1,4 W

## Trennübertrager Typ 9165

## Maximale Umgebungstemperatur

	Installation:	Einzelgerät	DIN-Schiene		pac-Träger	
	Einbaulage:	beliebig	vertikal	horizontal	vertikal	horizontal
Kanäle	Type:					
	Belüftung:	<b>Mit Umluft</b>				
1	9165/16-11-1 9165/16-11-10	70°C	70 °C	70 °C	70 °C	70 °C
2	9165/26-11-1 9165/26-11-10	70°C	60 °C	60 °C	60 °C	60 °C
	Belüftung:	<b>Ohne Umluft</b>				
1	9165/16-11-1 9165/16-11-10	70°C	60 °C	70 °C	60 °C	70 °C
2	9165/26-11-1 9165/26-11-10	70°C	50 °C	60 °C	45 °C	55 °C





## Verlustleistung

In den Datenblättern wird die max. Verlustleistung im Nennbetrieb (Ausgang 20 mA; Hilfsenergie 24 V DC; Last = 500 Ω) angegeben. Da in der Praxis nicht alle Geräte gleichzeitig unter Vollast betrieben werden, erfolgt die Projektierung üblicherweise mit einer durchschnittlichen Verlustleistung von 70 %. ( $P_{70\%}$ ).

Typ	Kanäle	max. Verlustleistung	70 % Verlustleistung
9165/16-11-1 9165/16-11-10	1	1,1 W	0,9 W
9165/26-11-1 9165/26-11-10	2	1,8 W	1,3 W

## Trennübertrager ohne Hilfsenergie Typ 9167

## Maximale Umgebungstemperatur

	Installation:	Einzelgerät	DIN-Schiene		pac-Träger	
	Einbaulage:	beliebig	vertikal	horizontal	vertikal	horizontal
Kanäle	Type:					
	Belüftung:	<b>Mit Umluft</b>				
1	<b>9167/13-11-0</b>	70 °C	70 °C	70 °C	70 °C	70 °C
2	<b>9167/23-11-0</b>	70 °C	70 °C	70 °C	70 °C	70 °C
	Belüftung:	<b>Ohne Umluft</b>				
1	<b>9167/13-11-0</b>	70 °C	70 °C	70 °C	70 °C	70 °C
2	<b>9167/23-11-0</b>	70 °C	70 °C	70 °C	70 °C	70 °C

## Verlustleistung

In den Datenblättern wird die max. Verlustleistung im Nennbetrieb (Signal 20 mA / 40 mA) angegeben.





Da in der Praxis nicht alle Geräte gleichzeitig unter Vollast betrieben werden, erfolgt die Projektierung üblicherweise mit einer durchschnittlichen Verlustleistung von 70 %. ( $P_{70\%}$ ).

Typ	Kanäle	max. Verlustleistung bei 20 mA / 40 mA	70 % Verlustleistung bei 20 mA / 40 mA
9167/13-11-0	1	0,2 W / 0,6 W	0,1 W / 0,4 W
9167/23-11-0	2	0,4 W / 1,2 W	0,2 W / 0,8 W



## Schaltverstärker Typ 9170

### Maximale Umgebungstemperatur

Kanäle	Installation:	Einzelgerät	DIN-Schiene		pac-Träger	
	Einbaulage:	beliebig	vertikal	horizontal	vertikal	horizontal
	Type:					
	Belüftung:	<b>Mit Umluft</b>				
1	9170/11-11-11 9170/11-12-11	70°C	70 °C	70 °C	70 °C	70 °C
	9170/11-14-1.	70°C	70 °C	70 °C	70 °C	70 °C
	9170/11-13-21	70°C	70 °C	70 °C	---*)	---*)
2	9170/21-10-11 9170/21-11-11 9170/21-12-11	70°C	65 °C	65 °C	60 °C	65 °C
	9170/21-14-1.	70°C	70 °C	70 °C	65 °C	65 °C
	9170/21-12-21	70°C	65 °C	65 °C	---*)	---*)
	Belüftung:	<b>Ohne Umluft</b>				
1	9170/11-11-11 9170/11-12-11	70°C	65 °C	65 °C	60 °C	65 °C
	9170/11-14-1.	70°C	70 °C	70 °C	65 °C	70 °C
	9170/11-13-21	70°C	65 °C	70 °C	---)*	---)*
2	9170/21-10-11 9170/21-11-11 9170/21-12-11	70°C	55 °C	60 °C	50 °C	55 °C
	9170/21-14-1.	70°C	65 °C	65 °C	60 °C	65 °C
	9170/21-12-21	70°C	55 °C	60 °C	---*)	---*)

\*) Varianten mit 230V AC Hilfsenergie nicht für Einsatz im pac-Träger geeignet





### Verlustleistung

In den Datenblättern wird die max. Verlustleistung im Nennbetrieb angegeben. Da in der Praxis nicht alle Geräte gleichzeitig unter Vollast betrieben werden, erfolgt die Projektierung üblicherweise mit einer durchschnittlichen Verlustleistung von 70 %. ( $P_{70\%}$ ).

Typ	Kanäle	max. Verlustleistung	70 % Verlustleistung
9170/11.-1.-1.	1	0,8 W	0,6 W
9170/21-1.-1.	2	1,3 W	0,9 W
9170/11-14-1.	1	0,6 W	0,4 W
9170/21-14-1.	1	0,9 W	0,4 W
9170/.1-1.-21	1	1,3 W	0,9 W
9170/21-1.-21	2	2 W	1,4 W

## Ex i Relais Modul Typ 9172

## Maximale Umgebungstemperatur

	Installation:	Einzelgerät	DIN-Schiene		pac-Träger	
	Einbaulage:	beliebig	vertikal	horizontal	vertikal	horizontal
Kanäle	Type:					
	Belüftung:	<b>Mit Umluft</b>				
2	9172/20-11-00 9172/21-11-00 9172/21-11-50 9172/22-11-00	70 °C	70 °C	70 °C	65 °C	70 °C
	Belüftung:	<b>Ohne Umluft</b>				
2	9172/20-11-00 9172/21-11-00 9172/21-11-50 9172/22-11-00	70 °C	70 °C	70 °C	65 °C	70 °C

## Verlustleistung





In den Datenblättern wird die max. Verlustleistung im Nennbetrieb angegeben. Da in der Praxis nicht alle Geräte gleichzeitig unter Vollast betrieben werden, erfolgt die Projektierung üblicherweise mit einer durchschnittlichen Verlustleistung von 70 %. ( $P_{70\%}$ ).

Typ	Kanäle	max. Verlustleistung	70 % Verlustleistung
9172/1.-...-	1	0,4 W	0,3 W
9172/2.-...-	2	0,8 W	0,6 W

**Bei Einsatz in Signalkreisen der funktionalen Sicherheit (SIL) sind die Geräte oft unter mit maximaler Verlustleistung im Einsatz. Ein Abschlag auf die durchschnittliche Verlustleistung ist in diesem Fall nicht zulässig.**

## Binärausgabe Typ 9175

## Maximale Umgebungstemperatur

Kanäle	Installation:	Einzelgerät	DIN-Schiene		pac-Träger	
	Einbaulage:	beliebig	vertikal	horizontal	vertikal	horizontal
	Type:					
	Belüftung:	<b>Mit Umluft</b>				
1	9175/10-12-1. 9175/10-14-1. 9175/10-16-1.	70 °C	60 °C	70 °C	40 °C	60 °C
2	9175/20-12-11 9175/20-14-11 9175/20-16-11	65 °C	nicht zulässig	55 °C	35 °C	55 °C
	Belüftung:	<b>Ohne Umluft</b>				
1	9175/10-12-1. 9175/10-14-1. 9175/10-16-1.	70 °C	50 °C	60 °C	nicht zulässig	40 °C
2	9175/20-12-11 9175/20-14-11 9175/20-16-11	65 °C	nicht zulässig	45 °C	nicht zulässig	nicht zulässig

## Verlustleistung





In den Datenblättern wird die max. Verlustleistung im Nennbetrieb (Ausgang max. Strom; Hilfsenergie 24 V DC) angegeben. Da in der Praxis nicht alle Geräte gleichzeitig unter Volllast betrieben werden, erfolgt die Projektierung üblicherweise mit einer durchschnittlichen Verlustleistung von 70 %. ( $P_{70\%}$ ).

Typ	Kanäle	max. Verlustleistung	70 % Verlustleistung
9175/10-12-1. 9175/10-14-1. 9175/10-16-1.	1	1.4 W	1 W
9175/20-12-11 9175/20-14-11 9175/20-16-11	2	2.4 W	1.7 W

Bei Einsatz in Signalkreisen der funktionalen Sicherheit (SIL) sind die Geräte oft unter mit maximaler Verlustleistung im Einsatz. Ein Abschlag auf die durchschnittliche Verlustleistung ist in diesem Fall nicht zulässig.

## Binärausgabe ohne Hilfsenergie Typ 9176

## Maximale Umgebungstemperatur

	Installation:	Einzelgerät	DIN-Schiene		pac-Träger	
	Einbaulage:	beliebig	vertikal	horizontal	vertikal	horizontal
Kanäle	Type:					
	Belüftung:	<b>Mit Umluft</b>				
1	<b>9176/10-1.-00</b>	70 °C	70 °C	70 °C	65 °C	70 °C
2	<b>9176/20-1.-00</b>	70 °C	60 °C	65 °C	55 °C	65 °C
	Belüftung:	<b>Ohne Umluft</b>				
1	<b>9176/10-1.-00</b>	70 °C	60 °C	65 °C	55 °C	65 °C
2	<b>9176/20-1.-00</b>	70 °C	50 °C	60 °C	45 °C	55 °C

## Verlustleistung

Die Verlustleistung  $P_V$  der Binärausgaben ohne Hilfsenergie ergibt sich aus der Differenz zwischen Ansteuerleistung  $P_E$  und benötigter Ausgangsleistung  $P_A$ :  $P_V = P_E - P_A$

Da in der Praxis nicht alle Geräte gleichzeitig unter Vollast betrieben werden, erfolgt die Projektierung üblicherweise mit einer durchschnittlichen Verlustleistung von 70 %. ( $P_{70\%}$ ).

Typ	Kanäle	max. Verlustleistung	70 % Verlustleistung
9176/*0-12-00	je Kanal	$P_V = (300 \text{ mW} + I_A * 15 \text{ mW/mA}) - (U_A * I_A)$	$0,7 * P_V$
9176/*0-14-00	je Kanal	$P_V = (380 \text{ mW} + I_A * 26 \text{ mW/mA}) - (U_A * I_A)$	$0,7 * P_V$
9176/*0-15-00	je Kanal	$P_V = (500 \text{ mW} + I_A * 37 \text{ mW/mA}) - (U_A * I_A)$	$0,7 * P_V$
9176/*0-16-00	je Kanal	$P_V = (500 \text{ mW} + I_A * 37 \text{ mW/mA}) - (U_A * I_A)$	$0,7 * P_V$
9176/*0-17-00	je Kanal	$P_V = (500 \text{ mW} + I_A * 37 \text{ mW/mA}) - (U_A * I_A)$	$0,7 * P_V$

$P_V$  [mW]: max. Verlustleistung





$U_A$  [V]: max. benötigte Ausgangsspannung

$I_A$  [mA]: max. benötigter Ausgangsstrom

**Bei Einsatz in Signalkreisen der funktionalen Sicherheit (SIL) sind die Geräte oft unter mit maximaler Verlustleistung im Einsatz. Ein Abschlag auf die durchschnittliche Verlustleistung ist in diesem Fall nicht zulässig.**

## Widerstandstrennübertrager Typ 9180

## Maximale Umgebungstemperatur

	Installation:	Einzelgerät	DIN-Schiene		pac-Träger	
	Einbaulage:	beliebig	vertikal	horizontal	vertikal	horizontal
Kanäle	Type:					
	Belüftung:	<b>Mit Umluft</b>				
1	9180/10-77-11 9180/11-77-11	70 °C	70 °C	70 °C	65 °C	70 °C
2	9180/20-77-11 9180/21-77-11	70 °C	65 °C	70 °C	60 °C	65 °C
	Belüftung:	<b>Ohne Umluft</b>				
1	9180/10-77-11 9180/11-77-11	70 °C	60 °C	65 °C	55 °C	65 °C
2	9180/20-77-11 9180/21-77-11	70 °C	55 °C	60 °C	50 °C	60 °C





## Verlustleistung

In den Datenblättern wird die max. Verlustleistung im Nennbetrieb (Ausgang max. Strom; Hilfsenergie 24 V DC) angegeben. Da in der Praxis nicht alle Geräte gleichzeitig unter Vollast betrieben werden, erfolgt die Projektierung üblicherweise mit einer durchschnittlichen Verlustleistung von 70 %. ( $P_{70\%}$ ).

Typ	Kanäle	max. Verlustleistung	70 % Verlustleistung
9180/10-77-11 9180/11-77-11	1	0,6 W	0,4 W
9180/20-77-11 9180/21-77-11	2	0,72 W	0,5 W

## Temperaturmessumformer 9182

## Maximale Umgebungstemperatur

	Installation:	Einzelgerät	DIN-Schiene		pac-Träger		
	Einbaulage:	beliebig	vertikal	horizontal	vertikal	horizontal	
Kanäle	Type:						
	Belüftung:	<b>Mit Umluft</b>					
1	9182/10-...-...	70 °C	70 °C	70 °C	50 °C	60 °C	
2	9182/20-...-...	70 °C	60 °C	70 °C	40 °C	55 °C	
	Belüftung:	<b>Ohne Umluft</b>					
1	9182/10-...-...	70 °C	45 °C	55 °C	40 °C	50 °C	
2	9182/20-...-...	70 °C	40 °C	50 °C	30 °C	50 °C	



## Verlustleistung

In den Datenblättern wird die max. Verlustleistung im Nennbetrieb angegeben. Da in der Praxis nicht alle Geräte gleichzeitig unter Vollast betrieben werden, erfolgt die Projektierung üblicherweise mit einer durchschnittlichen Verlustleistung von 70 %. ( $P_{70\%}$ ).

Typ	Kanäle	max. Verlustleistung	70 % Verlustleistung
9182/10-...-...	1	1,9 W	1,33 W
9182/20-...-...	2	1,9 W	1,33 W

## HART Multiplexer 9192

## Maximale Umgebungstemperatur

	Installation:	Einzelgerät	DIN-Schiene	
	Einbaulage:	beliebig	vertikal	horizontal
Kanäle	Type:			
	Belüftung:	Mit Umluft		
32	9192/32-10-10 )*	70 °C	70 °C	70 °C
	Belüftung:	Ohne Umluft		
32	9192/32-10-10 )*	70 °C	65 °C	70 °C

)\* HART Mux 9192 wird neben dem pac-Träger auf der Hutschiene montiert

## Verlustleistung

In den Datenblättern wird die max. Verlustleistung im Nennbetrieb angegeben. Da in der Praxis nicht alle Geräte gleichzeitig unter Vollast betrieben werden, erfolgt die Projektierung üblicherweise mit einer durchschnittlichen Verlustleistung von 70 %. ( $P_{70\%}$ ).

Typ	Kanäle	max. Verlustleistung	70 % Verlustleistung
9192/32-10-10	32	1,35 W	0,9 W

## 1 Information about this document

The cabinet installation guide should support you during engineering of the isolators ISpac 91xx. It provides important instructions for the installation of the devices into control cabinets. The guide does not replace the individual operating instructions. Please read the acc. operating instructions carefully before you start operating the isolators.

## 2 Planning

### 2.1 Planning of the cabinet power dissipation

The operation of the ISpac isolators creates a power dissipation which results into heat. This heat need to be dissipated from the place of its generation in order to protect the devices. If the maximum allowed ambient temperatures of the ISpac devices are exceeded it may result into a reduced life time.

The best way to dissipate the power is the use of a control cabinet with fan-and-filter units or cooling units. Such a design provides a better heat dissipation than a cabinet without fan-and-filter or an installation in an open rack.

In order to select the way of installation and the measures for a sufficient heat dissipation we recommend the following steps:

1. **Determine the ambient temperature of the cabinet / the room of installation**
2. **Does the enclosure require a particular protection category to EN 60529?**
3. **Calculate the maximum power dissipation of all installed electronic devices**  
This document includes the data for the power dissipation of all ISpac types. Please multiply these values with the number of devices. Add the values of additional installed devices, like the power supply.
4. **Determine the maximum allowed temperature within the cabinet**  
This document includes the data for the maximum allowed temperature for all ISpac devices installed in a cabinet or in an open rack. The maximum temperature depends e.g. on the orientation of the devices. Please note that this is an important issue when planning the cabinet design.
5. **Select the suitable heat dissipation method**

#### a) Closed cabinets (without outlet / filter-and-fan unit)

Application	Moderate dissipated power and the cabinet is operated in a dusty or harsh environment, the temperature outside the cabinet / enclosure is lower than the temperature inside.
Calculation of max. dissipated power	$P_{max} = \Delta T * S * K$ <div style="display: flex; justify-content: space-between;"> <div style="width: 30%;"> <p><math>P_{max}</math> [W]</p> <p><math>\Delta T</math> [°C]</p> <p>S [m<sup>2</sup>]</p> <p>K [(W/m<sup>2</sup>*°C)]</p> </div> <div style="width: 65%;"> <p>max. allowed power dissipation in the cabinet</p> <p>max. allowed temperature rise</p> <p>free, heat radiating surface of the cabinet</p> <p>thermal radiating coefficient (K=5.5 for coated steel sheets), please contact the cabinet vendor for detailed information</p> </div> </div>

The calculated value  $P_{max}$  has to be lower than the sum of the average dissipation power (70% of the maximum dissipation power) of the installed devices:  $P_{max} > \sum P_{70\%}$ .



Please pay attention on the influence of solar radiation. The combination of a high ambient temperature and direct sun light on the surface of the enclosure could easily result in an excessive operating temperature for the devices. We recommend to use a suitable sun roof.

**b) Cabinets with outlets and open racks (without fan-and-filter units)**

Application	Moderate dissipation power and air-conditioned rooms, pay attention on sufficient room between the devices to allow an air-flow around the devices
Calculation of max. dissipated power	See case a) Depending on the implementation the allowed maximum dissipation power can be doubled compared to case a).

The calculated value  $P_{max}$  has to be lower than the sum of the average dissipation power (70% of the maximum dissipation power) of the installed devices:  $P_{max} > \sum P_{70\%}$ .

**c) Cabinets with filter-and-fan units and outlets**

Application	Medium or high dissipated power. One or more fans create an air flow from the bottom of the cabinet flowing around the devices and exiting the enclosure at the upper part of the cabinet.  The temperature outside of the cabinet has to be lower than the minimum allowed max. operating temperature of all devices installed in the cabinet.						
Calculation of the required air flow	See case a), a part of the heat is radiated by the surface. in the second step it is necessary to calculate the required performance of the filter-and-fan units.  <b><math>Q = (3,1 * P_{70\%}) / \Delta T</math></b> <table style="width: 100%; border: none;"> <tr> <td style="width: 50%;">Q [m³/h]</td> <td>required air flow</td> </tr> <tr> <td>P<sub>70%</sub> [W]</td> <td>dissipated power (70 % of max. power dissipation)</td> </tr> <tr> <td>ΔT [°C]</td> <td>allowed temperature rise in the cabinet</td> </tr> </table>	Q [m³/h]	required air flow	P <sub>70%</sub> [W]	dissipated power (70 % of max. power dissipation)	ΔT [°C]	allowed temperature rise in the cabinet
Q [m³/h]	required air flow						
P <sub>70%</sub> [W]	dissipated power (70 % of max. power dissipation)						
ΔT [°C]	allowed temperature rise in the cabinet						

- When installing the control cabinet on a raised floor, the bottom of the control cabinet must be sealed against the raised floor.

**d) Air conditioned / cooled cabinets**

Application	Very high dissipation power and/or an ambient temperature which is higher than the minimum allowed max. operating temperature of all devices installed in the cabinet.
Calculation	See case a), the performance of the air conditioning unit has to be selected according to the overall dissipation power of all devices installed in the cabinet.

## 2.2 Standard design based on vertical DIN rail of a control cabinet

The described design of a control cabinet is based on an extended test project which lasted over several months. Especially, this is important for the maximum lifetime of the installed components and interpretation of ambient conditions.

The design is based on a cabinet with the dimensions (H x W x D) of 2000 x 800 x 800 mm. The test cabinet is divided in the middle by two mounting plates.

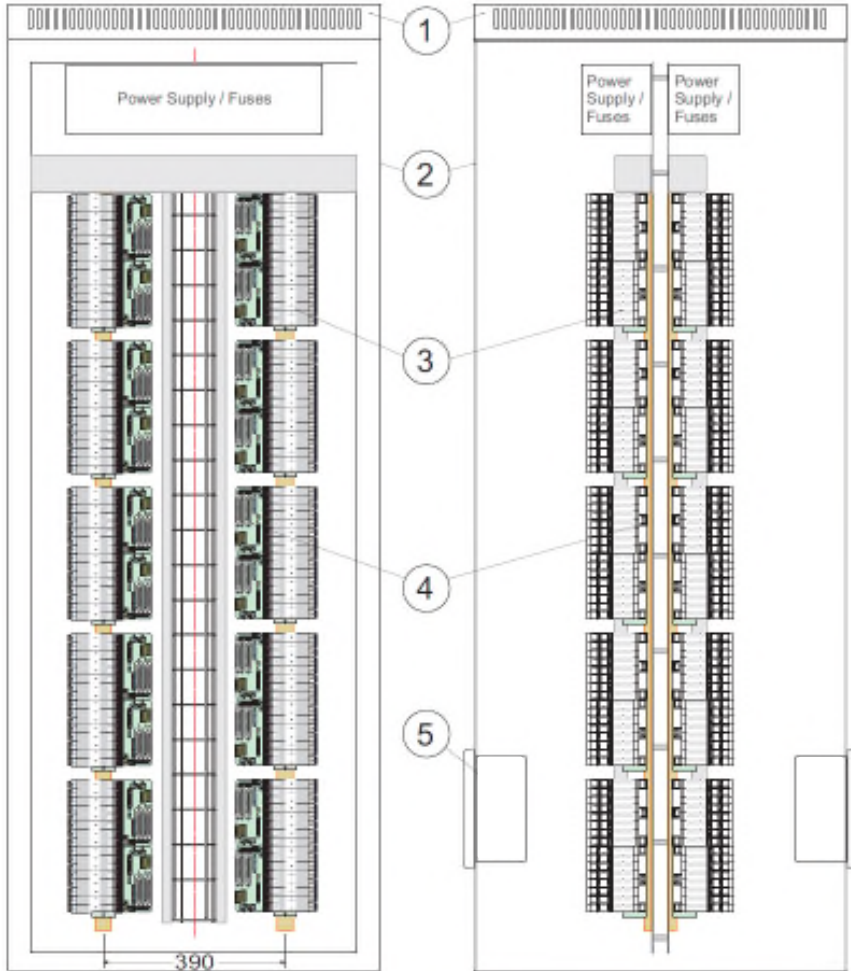

Fig 1 Standard design based on vertical DIN rail in the control cabinet

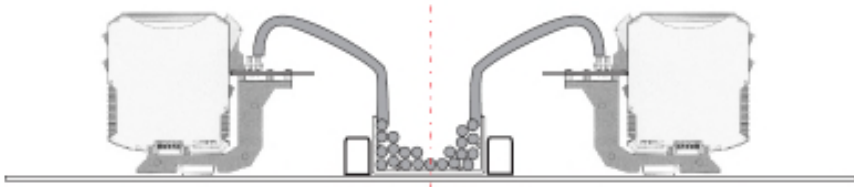

Fig. 2 View (cross section) of the pac-Carrier and cable duct

**Special feature of the design:**

With this design the cabinet can be fitted with up to 40 pac-Carrier.

#	Description	Volume	Vendor	Ordering#
1	Roof plate	1	Rittal	9659.535
2	Control cabinet	1	Rittal	8808.750
3	ISpac (one-/ duel channel modul)	Up to 640 channels	R. STAHL	*)
4	pac-Carrier			
	with 8 Slots	up to 40	R. STAHL	9195*)
	with 16 Slots	up to 20	R. STAHL	9195*)
5	TopTherm fan-and-filter units	2 x 2	Rittal	3240.100

\*) See the specific order no. in the Engineering Guide

<b>i</b>	<ul style="list-style-type: none"> <li>• Only the spacer of R. Stahl (244971) must be used between the pac- Carriers on vertical DIN rail of a control cabinet.</li> <li>• Use a DIN rail holder at the end on vertical DIN rail to prevent the slipping of the pac-Carrier on the DIN rail.</li> </ul>
----------	---

### 2.3 Best practice for the installation of devices in a control cabinet

In extension to the above described and recommended design, the following rules have to be observed:

1. Pay attention that the sum of the dissipated power of all installed devices must be lower than the calculated or stated maximum allowed dissipation power of the cabinet or enclosure. You may use calculation software like Rittal Therm.
2. The ISpac devices and the pac-Carrier can be installed in horizontal or vertical orientation. The horizontal installation allows a better heat dissipation than the vertical one.
3. Install the devices with the higher dissipation e.g. power supply units power on the upper part of the cabinet.
4. If you do not follow the recommended cabinet design, ensure that the air may flow around the devices. There has to be sufficient space between the devices and the cable ducts. We recommend a distance of minimum 6 cm (Please refer to figures 2 and 3). We recommend to use spacer in order to place the devices better into the air flow in the cabinet.
5. Pay attention during the installation, that the system cables (between pac-Carrier and I/O-module of the control system) does not block the air flow.
6. Pay attention that the labeling of the wiring does not block the air flow.
7. The filter for the out-or inlets and the fan-and-filter has to be checked and exchanged on regular base.
8. When installing the control cabinet with fans (ventilation) on a raised floor, the bottom of the control cabinet must be sealed against the raised floor.

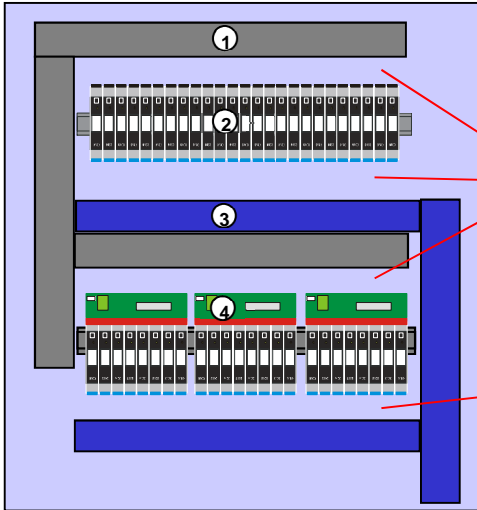

- 1 Standard cable duct
- 2 Isolator/Barrier ISpac
- 3 Ex i cable duct
- 4 Isolator in pac-Carrier

Keep distance between devices and cable ducts of min. 6 cm

Figure 6 Horizontal installation in the cabinet

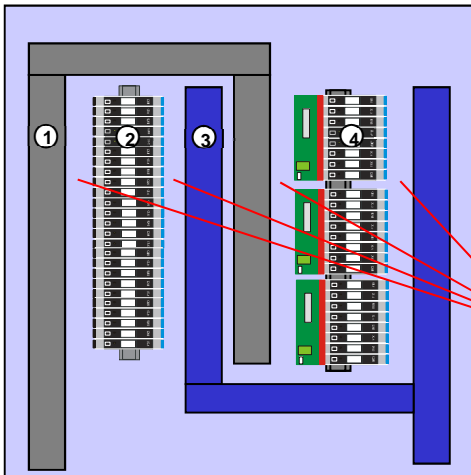

- 1 Standard cable duct
- 2 Isolator/Barrier ISpac
- 3 Ex i cable duct
- 4 Isolator in pac-Carrier

Keep distance between devices and cable ducts of min. 6 cm.

Keep distance (vertical) between pac- Carriers or an amount of 16 devices of min. 3 cm.

Figure 7 Vertical installation in the cabinet

## 2.4 Max. ambient temperatures



The ISpac isolators can be used over a wide temperature range. Depending on the isolator version and installation method different maximum ambient temperatures may result.

On the following pages you may find the maximum ambient temperatures for the individual ISpac isolator type.

The given limits represent the temperature measured in a distance of approx. 2...3 cm to the unit. The surface of the isolators may reach higher values. We recommend to verify the compliance to the limits by means of a temperature measurement after the installation.

### Ex i power supply type 9143





#### Maximum ambient temperature

	Installation:	<b>Single unit</b>	<b>DIN-rail</b>	
	Orientation:	<b>any</b>	<b>vertical</b>	<b>horizontal</b>
Channels	Type:			
	Ventilation:	<b>with ventilation</b>		
1	<b>9143/1.-...-...-...</b>	70°C	70°C	70°C
	Ventilation:	<b>without ventilation</b>		
1	<b>9143/1.-...-...-...</b>	70°C	70°C	70°C

Power supply	Typ	max. power dissipation (24 V DC) [W]	max. power dissipation (115 / 230 V AC) [AV]	70 % power dissipation
24 V AC / DC	9143/10-065-200-10s	1,70		1,19
	9143/10-099-220-10s	3,18		2,23
	9143/10-104-220-10s	3,10		2,17
	9143/10-114-200-10s	2,73		1,91
	9143/10-124-150-10s	1,77		1,24
	9143/10-156-160-10s	1,94		1,36
	9143/10-187-050-10s	1,38		0,97
	9143/10-244-060-10s	1,88		1,32
85V ... 230V AC	9143/10-187-050-20s		1,38 / 2,58	0,97 / 1,8
	9143/10-156-160-20s		1,94 / 2,84	1,36 / 1,99
	9143/10-124-150-20s		1,27 / 1,97	0,89 / 1,38
	9143/10-114-200-20s		1,83 / 2,63	1,28 / 1,84
	9143/10-104-220-20s		2,10 / 2,7	1,47 / 1,89
	9143/10-065-200-20s		1,40 / 2,4	0,98 / 1,68
	9143/10-244-060-20s		1,68 / 2,88	1,18 / 2,02

Frequency transmitter type 9146

Maximum ambient temperature





	Installation:	<b>Single unit</b>	<b>DIN-rail</b>		<b>pac-Carrier</b>	
	Orientation:	<b>any</b>	<b>vertical</b>	<b>horizontal</b>	<b>vertical</b>	<b>horizontal</b>
Channels	Type:					
	Ventilation:	<b>with ventilation</b>				
1	<b>9146/10-11-12</b>	70°C	65°C	70°C	55°C	60°C
2	<b>9146/20-11-11</b>	70°C	65°C	70°C	55°C	60°C
	Ventilation:	<b>without ventilation</b>				
1	<b>9146/10-11-12</b>	70°C	50°C	65°C	40°C	60°C
2	<b>9146/20-11-11</b>	70°C	50°C	65°C	40°C	60°C

Data sheets are describing the maximum power dissipation in standard operation (output 20 mA; power supply 24 V DC; load = 250 Ω). In practice not all isolators are working with full load. Therefore engineering is done typically with an average power dissipation of 70 % (P<sub>70%</sub>).

Type	Channels	max. power dissipation	70 % power dissipation
9146/10-11-2	1	1.1 W	0.8 W
9146/20-11-11	2	1.5 W	1.05 W

**Vibration transmitter supply unit type 9147**

**Maximum ambient temperature**

		Installation: <b>Single unit</b>	<b>DIN-rail</b>		<b>pac-Carrier</b>	
		Orientation: <b>any</b>	<b>vertical</b>	<b>horizontal</b>	<b>vertical</b>	<b>horizontal</b>
<b>Channels</b>	<b>Type:</b>					
	Ventilation::	<b>with ventilation</b>				
1	<b>9147/10-99-10</b>	70°C	70°C	60°C	50°C	60°C
2	<b>9147/20-99-10</b>	65°C	65°C	60°C	50°C	55°C
		<b>without ventilation</b>				
1	<b>9147/10-99-10</b>	70°C	50°C	55°C	40°C	45°C
2	<b>9147/20-99-10</b>	65°C	45°C	45°C	30°C	40°C

**Power dissipation**





Data sheets are describing the maximum power dissipation in standard operation. In practice not all isolators are working with full load. Therefore engineering is done typically with an average power dissipation of 70 % ( $P_{70\%}$ ).

<b>Type</b>	<b>Channels</b>	<b>max. power dissipation</b>	<b>70 % power dissipation</b>
9147/10-99-10	1	1.35 W	0.95 W
9147/20-99-10	2	1.7 W	1.2 W



**Transmitter supply unit type 9160**

**Maximum ambient temperature**

		Installation: <b>Single unit</b>	<b>DIN-rail</b>		<b>pac-Carrier</b>	
		Orientation: <b>any</b>	<b>vertical</b>	<b>horizontal</b>	<b>vertical</b>	<b>horizontal</b>
<b>Channels</b>	<b>Type:</b>					
	Ventilation:	<b>with ventilation</b>				
1	<b>9160/13-1-..</b>	70°C	70 °C	70 °C	60 °C	60 °C
	<b>9160/19-1-..</b>	70°C	60 °C	60 °C	50 °C	50 °C
2	<b>9160/23-1-..</b>	70°C	60 °C	60 °C	50 °C	50 °C
		<b>without ventilation</b>				
1	<b>9160/13-1-..</b>	70°C	60 °C	65 °C	55 °C	60 °C
	<b>9160/19-1-..</b>	70°C	45 °C	50 °C	30 °C	45 °C
2	<b>9160/23-1-..</b>	70°C	45 °C	50 °C	30 °C	45 °C





**Power dissipation**

Data sheets are describing the maximum power dissipation in standard operation (output 20 mA; power supply 24 V DC; load = 250 Ω). In practice not all isolators are working with full load. Therefore engineering is done typically with an average power dissipation of 70 % ( $P_{70\%}$ ).

<b>Type</b>	<b>Channels</b>	<b>max. power dissipation</b>	<b>70 % power dissipation</b>
9160/1.-11-10 9160/1.-11-11	1	1,4 W	1 W
9160/13-11-13	1	1,8 W	1,26 W
9160/2.-11-11 9160/23-10-10	2	2,3 W	1,61 W

**Transmitter supply unit with limit values type 9162**

**Maximum ambient temperatures**

	Installation:	<b>Single unit</b>	<b>DIN-rail</b>		<b>pac-Carrier</b>	
	Orientation:	<b>any</b>	<b>vertical</b>	<b>horizontal</b>	Orientation:	<b>any</b>
Channels	Type:					
		Ventilation:	<b>with ventilation</b>			
1	<b>9162/13-11-..</b>	70°C	58°C	60°C	52°C	60°C
	Ventilation:	<b>without ventilation</b>				
1	<b>9162/13-11-..</b>	70°C	48°C	56°C	35°C	50°C





**Power dissipation**

Data sheets are describing the maximum power dissipation in standard operation (output 20 mA; power supply 24 V DC; load = 250 Ω). In practice not all isolators are working with full load. Therefore engineering is done typically with an average power dissipation of 70 % (P<sub>70%</sub>).

Type	max. power dissipation	70 % power dissipation
9162/13-11-..	1.5 W	1.05W

**Isolating Repeater HART Input Type 9163**

**Maximum ambient temperature**

	Installation:	Single unit	DIN-rail		pac-Carrier	
	Orientation:	any	vertical	horizontal	vertical	horizontal
Channels	Type:					
	Ventilation:	<b>with ventilation</b>				
1	<b>9163/11-81-10</b>	70°C	70°C	70°C	70°C	70°C
2	<b>9163/23-1.-1.</b>	70°C	70°C	70°C	60 °C	70°C
	Ventilation:	<b>without ventilation</b>				
1	<b>9163/11-81-10</b>	70°C	60 °C	70 °C	55 °C	65 °C
2	<b>9163/23-1.-1.</b>	70°C	50 °C	60 °C	45 °C	60 °C





**Power dissipation**

Data sheets are describing the maximum power dissipation in standard operation (output 20 mA; power supply 24 V DC; load = 250 Ω). In practice not all isolators are working with full load. Therefore engineering is done typically with an average power dissipation of 70 % ( $P_{70\%}$ ).

Type	Channels	max. power dissipation	70 % power dissipation
9163/11-81-10	1	0.7 W	0.5 W
9163/23-1.-1.	2	2 W	1.4 W

**Isolating Repeater Output Type 9165**

**Maximum ambient temperature**

		Installation: <b>Single unit</b>	<b>DIN-rail</b>		<b>pac-Carrier</b>	
		Orientation: <b>any</b>	<b>vertical</b>	<b>horizontal</b>	<b>vertical</b>	<b>horizontal</b>
Channels	Type:					
	Ventilation:	<b>with ventilation</b>				
1	<b>9165/16-11-.1</b> <b>9165/16-11-10</b>	70°C	70 °C	70 °C	70 °C	70 °C
2	<b>9165/26-11-.1</b> <b>9165/26-11-10</b>	70°C	60 °C	60 °C	60 °C	60 °C
		<b>without ventilation</b>				
1	<b>9165/16-11-.1</b> <b>9165/16-11-10</b>	70°C	60 °C	70 °C	60 °C	70 °C
2	<b>9165/26-11-.1</b> <b>9165/26-11-10</b>	70°C	50 °C	60 °C	45 °C	55 °C





**Power dissipation**

Data sheets are describing the maximum power dissipation in standard operation (output 20 mA; power supply 24 V DC; load = 500 Ω). In practice not all isolators are working with full load. Therefore engineering is done typically with an average power dissipation of 70 % (P<sub>70%</sub>).

Type	Channels	max. power dissipation	70 % power dissipation
9165/16-11-.1 9165/16-11-10	1	1.1 W	0.9 W
9165/23-11-.1 9165/23-11-10	2	1.8 W	1.3 W

**Isolating Repeater Loop Powered Type 9167**

**Maximum ambient temperature**

	Installation:	Single unit	DIN-rail		pac-Carrier	
	Orientation:	any	vertical	horizontal	vertical	horizontal
Channels	Type:					
	Ventilation:	with ventilation				
1	9167/11-11-00 9167/13-11-0 9167/14-11-00	70°C	70 °C	70 °C	70 °C	70 °C
2	9167/21-11-00 9167/23-11-0 9167/24-11-00	70°C	70 °C	70 °C	70 °C	70 °C
	Ventilation:	without ventilation				
1	9167/11-11-00 9167/13-11-0 9167/14-11-00	70°C	70 °C	70 °C	70 °C	70 °C
2	9167/21-11-00 9167/23-11-0 9167/24-11-00	70°C	70 °C	70 °C	70 °C	70 °C





**Power dissipation**

Data sheets are describing the maximum power dissipation in standard operation (Signal 20 mA / 40 mA). In practice not all isolators are working with full load. Therefore engineering is done typically with an average power dissipation of 70 % ( $P_{70\%}$ ).

Type	Channels	max. power dissipation at 20 mA / 40 mA	70 % power dissipation at 20 mA / 40 mA
9167/11-11-00 9167/13-11-0 9167/14-11-00	1	0.2 W / 0.6 W	0.1 W / 0.4 W
9167/21-11-00 9167/23-11-0 9167/24-11-00	2	0.4 W / 1.2 W	0.2 W / 0.8 W

**Switching Repeater Type 9170**

**Maximum ambient temperature**

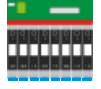
	Installation:	Single unit	DIN-rail		pac-Carrier	
	Orientation:	any	vertical	horizontal	vertical	horizontal
Channels	Type:					
Ventilation:		<b>with ventilation</b>				
1	9170/11-11-11 9170/11-12-11	70 °C	70 °C	70 °C	70 °C	70 °C
	9170/11-14-1.	70 °C	70 °C	70 °C	70 °C	70 °C
	9170/11-13-21	70 °C	70 °C	70 °C	---*)	---*)
2	9170/21-10-11 9170/21-11-11 9170/21-12-11	70 °C	65 °C	65 °C	60 °C	65 °C
	9170/21-14-1.	70 °C	70 °C	70 °C	65 °C	65 °C
	9170/21-12-21	70 °C	65 °C	65 °C	---*)	---*)
Ventilation:		<b>without ventilation</b>				
1	9170/11-11-11 9170/11-12-11	70 °C	65 °C	65 °C	60 °C	65 °C
	9170/11-14-1.	70 °C	70 °C	70 °C	65 °C	70 °C
	9170/11-13-21	70 °C	65 °C	70 °C	---)*	---)*
2	9170/21-10-11 9170/21-11-11 9170/21-12-11	70 °C	55 °C	60 °C	50 °C	55 °C
	9170/21-14-1.	70 °C	65 °C	65 °C	60 °C	65 °C
	9170/21-12-21	70 °C	55 °C	60 °C	---*)	---*)

\*) Versions with 230V AC power supply can not be used for pac-Carriers





**Power dissipation**

Data sheets are describing the maximum power dissipation in standard operation. In practice not all isolators are working with full load. Therefore engineering is done typically with an average power dissipation of 70 % (P<sub>70%</sub>).

Type	Channels	max. power dissipation	70 % power dissipation
9170/1.-1.-1.	1	0,8 W	0,6 W
9170/2.-1.-1.	2	1,3 W	0,9 W
9170/11-14-1.	1	0,6 W	0,4 W
9170/21-14-1.	1	0,9 W	0,4 W
9170/1-1.-21	1	1,3 W	0,9 W
9170/20-1.-21	2	2 W	1,4 W

**I.S. Relay Module Type 9172**

**Maximum ambient temperature**

	Installation:	Single unit	DIN-rail		pac-Carrier	
	Orientation:	any	vertical	horizontal	Orientation:	any
Channels	Type:					
	Ventilation:	<b>with ventilation</b>				
2	9172/20-11-00 9172/21-11-00	70 °C	70 °C	70 °C	65 °C	70 °C
	Ventilation:	<b>without ventilation</b>				
2	9172/20-11-00 9172/21-11-00	70 °C	70 °C	70 °C	65 °C	70 °C

**Power dissipation**





Data sheets are describing the maximum power dissipation in standard operation. In practice not all isolators are working with full load. Therefore engineering is done typically with an average power dissipation of 70 % ( $P_{70\%}$ ).

Type	Channels	max. power dissipation	70 % power dissipation
9172/2.-.-.-.	2	0.8 W	0.6 W

The devices are operating with maximum dissipation power in case that the devices are used for functional safety functions (SIL). A derating of the power dissipation is not allowed in this case.

Digital Output Type 9175

Maximum ambient temperature

	Installation:	Single unit	DIN-rail		pac-Carrier	
	Orientation:	any	vertical	horizontal	Orientation:	any
Channels	Type:					
	Ventilation:	with ventilation				
1	9175/10-14-1. 9175/10-16-1.	70 °C	60 °C	70 °C	40 °C	60 °C
2	9175/20-12-11 9175/20-14-11 9175/20-16-11	65 °C	not allowed	55 °C	35 °C	55 °C
	Ventilation:	with ventilation				
1	9175/10-14-1. 9175/10-16-1.	70 °C	50 °C	60 °C	not allowed	40 °C
2	9175/20-12-11 9175/20-14-11 9175/20-16-11	65 °C	not allowed	45 °C	not allowed	not allowed

Power dissipation

Data sheets are describing the maximum power dissipation in standard operation (output max. current; power supply 24 V DC). In practice not all isolators are working with full load. Therefore engineering is done typically with an average power dissipation of 70 % (P<sub>70%</sub>).





Type	Channels	max. power dissipation	70 % power dissipation
9175/10-14-11 9175/10-16-11	1	1.4 W	1 W
9175/20-12-11 9175/20-14-11 9175/20-16-11	2	2.4 W	1.7 W

The devices are operating with maximum dissipation power in case that the devices are used for functional safety functions (SIL). A derating of the power dissipation is not allowed in this case.



Digital Output Loop Powered Type 9176

Maximum ambient temperature

	Installation:	Single unit	DIN-rail		pac-Carrier	
	Orientation:	any	vertical	horizontal	Orientation:	any
Channels	Type:					
	Ventilation:	with ventilation				
1	9176/10-1.-00	70 °C	70 °C	70 °C	65 °C	70 °C
2	9176/20-1.-00	70 °C	60 °C	65 °C	55 °C	65 °C
	Ventilation:	without ventilation				
1	9176/10-1.-00	70 °C	60 °C	65 °C	55 °C	65 °C
2	9176/20-1.-00	70 °C	50 °C	60 °C	45 °C	55 °C

Power dissipation

The power dissipation  $P_V$  of the Digital Output Loop Powered can be calculated from the difference between control power  $P_E$  and required output power  $P_A$ :  $P_V = P_E - P_A$

In practice not all isolators are working with full load. Therefore engineering is done typically with an average power dissipation of 70 % ( $P_{70\%}$ ).





Type	Channels	max. power dissipation	70 % power dissipation
9176/*0-12-00	per channel	$P_V = (300 \text{ mW} + I_A * 15 \text{ mW/mA}) - (U_A * I_A)$	$0,7 * P_V$
9176/*0-14-00	per channel	$P_V = (380 \text{ mW} + I_A * 26 \text{ mW/mA}) - (U_A * I_A)$	$0,7 * P_V$
9176/*0-15-00	per channel	$P_V = (500 \text{ mW} + I_A * 37 \text{ mW/mA}) - (U_A * I_A)$	$0,7 * P_V$
9176/*0-16-00	per channel	$P_V = (500 \text{ mW} + I_A * 37 \text{ mW/mA}) - (U_A * I_A)$	$0,7 * P_V$
9176/*0-17-00	per channel	$P_V = (500 \text{ mW} + I_A * 37 \text{ mW/mA}) - (U_A * I_A)$	$0,7 * P_V$

- $P_V$  [mW]: max. power dissipation
- $U_A$  [V]: max. required output voltage
- $I_A$  [mA]: max. required output current

The devices are operating with maximum dissipation power in case that the devices are used for functional safety functions (SIL). A derating of the power dissipation is not allowed in this case.

**Resistance isolator type 9180**

**Maximum ambient temperature**

	Installation:	Single unit	DIN-rail		pac-Carrier	
	Orientation:	any	vertical	horizontal	Orientation:	any
Channels	Type:					
	Ventilation:	<b>with ventilation</b>				
1	9180/10-77-11 9180/11-77-11	70 °C	70 °C	70 °C	65 °C	70 °C
2	9180/20-77-11 9180/21-77-11	70 °C	65 °C	70 °C	60 °C	65 °C
	Ventilation:	<b>without ventilation</b>				
1	9180/10-77-11 9180/11-77-11	70 °C	60 °C	65 °C	55 °C	65 °C
2	9180/20-77-11 9180/21-77-11	70 °C	55 °C	60 °C	50 °C	60 °C





**Power dissipation**

Data sheets are describing the maximum power dissipation in standard operation. In practice not all isolators are working with full load. Therefore engineering is done typically with an average power dissipation of 70 % ( $P_{70\%}$ ).

Type	Channels	max. power dissipation	70 % power dissipation
9180/10-77-11 9180/11-77-11	1	0,6 W	0,4 W
9180/20-77-11 9180/21-77-11	2	0,72 W	0,5 W

**Temperature Transmitter Type 9182**

**Maximum ambient temperature**

Channels	Installation:	Single unit	DIN-rail		pac-Carrier	
	Orientation:	any	vertical	horizontal	Orientation:	any
Type:						
Ventilation:	<b>with ventilation</b>					
1	<b>9182/10-...-...</b>	70 °C	70 °C	70 °C	50 °C	60 °C
2	<b>9182/20-...-...</b>	70 °C	60 °C	70 °C	40 °C	55 °C
Ventilation:	<b>without ventilation</b>					
1	<b>9182/10-...-...</b>	70 °C	45 °C	55 °C	40 °C	50 °C
2	<b>9182/20-...-...</b>	70 °C	40 °C	50 °C	30 °C	50 °C



**Power dissipation**

Data sheets are describing the maximum power dissipation in standard operation (output 20 mA; power supply 24 V DC; load = 250 Ω). In practice not all isolators are working with full load. Therefore engineering is done typically with an average power dissipation of 70 % ( $P_{70\%}$ ).

Type	Channels	max. power dissipation	70 % power dissipation
9182/10-...-...	1	1.9 W	1.33 W
9182/20-...-...	2	1.9 W	1.33 W

**HART Multiplexer Type 9192**

**Maximum ambient temperature**

	Installation:	<b>Single unit</b>	<b>DIN-rail</b>	
	Orientation:	<b>any</b>	<b>vertical</b>	<b>horizontal</b>
Channels	Type:			
	Ventilation:	<b>with ventilation</b>		
32	<b>9192/32-10-10</b>	70 °C	70 °C	70 °C
	Ventilation:	<b>without ventilation</b>		
32	<b>9192/32-10-10</b>	70 °C	65 °C	70 °C

)\* HART Mux 9192 are mounted beside the pac-Carrier

**Power dissipation**

Data sheets are describing the maximum power dissipation in standard operation. In practice not all isolators are working with full load. Therefore engineering is done typically with an average power dissipation of 70 % ( $P_{70\%}$ ).

Type	Channels	max. power dissipation	70 % power dissipation
9192/32-10-10	32	1.35 W	0.9 W



R. STAHL Schaltgeräte GmbH  
Am Bahnhof 30  
74638 Waldenburg (Württ.) – Germany  
[r-stahl.com](http://r-stahl.com)

S-CIG-ISpac-007-de/en-02/2022