



THE STRONGEST LINK.

STAHL

**UPS
UNINTERRUPTIBLE POWER SUPPLY**



CUSTOMIZED SYSTEM SOLUTIONS

In times of increasing relevance of decentral power supplies and decreasing reliability of the power supply networks, uninterruptable power supplies (UPS) become more and more important. Especially for applications which are safety critical, applications with a high requirement concerning the plant availability, lighting systems e.g. for helidecks on ships or PLC systems which would cause a high damage in case of data loss, UPS systems more often belong to the basic equipment of the plant. R. STAHL, with its more than 80 years of experience in explosion protection, is able to transfer the requirements of a modern UPS system into systems, which are suitable for use in explosion-protected areas.

R. STAHL is able to deliver complete systems beginning with terminal boxes over AC or DC distribution boards up to UPS systems with battery boxes and also off-grid solutions can be scope of supply. Therefore R. STAHL is able to revert on a wide spectrum of standard products and solutions and if the standard is not feasible for the customer's requirements, R. STAHL with its longtime experience, its knowhow and its qualified employees is able to prepare customized solutions, which perfectly match the requirements of the customer.

R. STAHL is the strongest link

BENEFITS

- 100% process safety
- Reliable battery backup
- Standardized solutions
- System solutions customized to your needs
- VRLA, NiCd, Li-Ion battery or capacitors as buffer technology available
- Competent technical support prior, during and after purchase
- Maximum safety in explosion-protected areas
- Solutions for the most extreme environmental conditions (i.e. heat, cold, humidity or marine atmosphere)



SYSTEM DESIGN

R. STAHL can supply various types of UPS systems. The design can be either a standard design, based on the expertise of R. STAHL, or a design based on customer requirements. Depending on the demands of reliability and fault safety, the appropriate system can be engineered. Options for designs can be without redundancy, with partly redundant elements and 100 % redundant systems. Also the criteria to use modular or monoblock design has influence on availability and fault safety.

Non redundant UPS

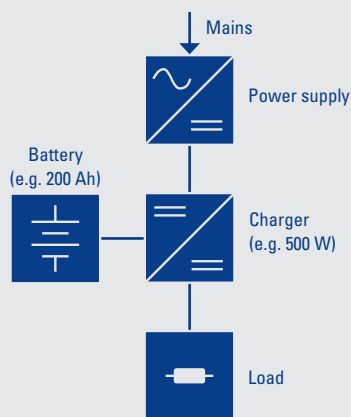

A UPS system without redundancy is a typical solution for loads which are not safety relevant in case of black out. This is the easiest solution for a UPS system. In case of a failure of the charger, the battery or any other device which is necessary for the function of the UPS, the load cannot be powered if the mains fails at the same time. A bypass switch or static transfer switch can also be included in UPS systems. Typical applications for such UPS systems are machines for production, aviation light supply, helideck lighting, HMI systems, elevators, cranes, pumps, valves, etc.

Partly or fully redundant UPS

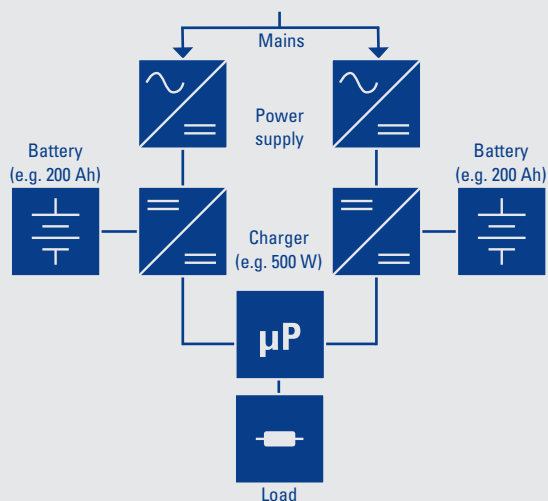

A redundant UPS is typically used for loads which are safety relevant in case of a black out. Typical system design for partly redundant systems is a 100 % redundancy of the charger and 50 % redundancy of the battery banks. A fully redundant system would also have 100 % redundant battery banks. Also in case of a dual failure (e.g. one battery bank and one charger at the same time) the load will still be powered. A partly redundant system will also supply the load in that case but with reduced buffer time. Typical applications for redundant systems are power supply for BOPs, telemetry systems, safety critical systems, etc.



Sample of a R. STAHL partly redundant UPS system in monoblock design

Monoblock design

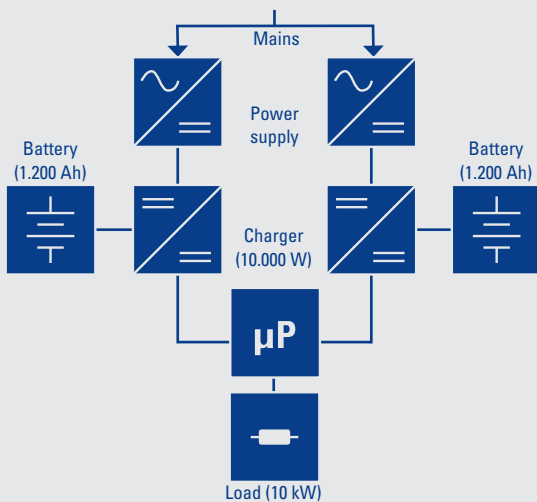

Monoblock design for UPS systems means that the charger is designed to supply the complete load. E.g. if the load is 10 kW, the charger is able to power the 10 kW load. For a redundant design two chargers with each 10 kW are necessary. The result is a spare capacity of 100 % which is not used in normal operation. The limit for monoblock design is based on heat loss and space inside the Ex d enclosures.

Modular design

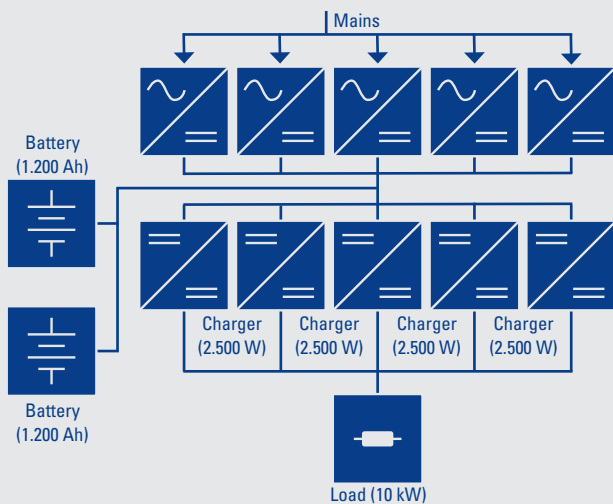

Modular designed UPS systems consist of several chargers. This scalable design is perfect for high power UPS systems. But also for redundant systems this design can be used. 1+N redundancy can be built up which means that the spare capacity can be reduced to e.g. 25 % with the same availability as a 100 % redundant monoblock design UPS. Even exchange of modules during operation is possible with such a design.

CAPACITOR UPS



MAIN FEATURES

- Extremely short charging time, which means ready for operation within seconds
- USB port and shut-down software for connection to PC systems
- Output up to 40A DC
- Backup time range - 1s up to a few minutes (customize up to a few hours)

TYPICAL APPLICATIONS

Backup for PC, PLC, HMI and low power applications like sensors

BENEFITS

The 100% maintenance-free Capacitor UPS provides 20 years of service life, even at high temperatures. It comes with a lightweight and compact design, and if required, energy storage modules can be added to increase backup time.

- The capacitor UPS is especially designed to prevent PCs, HMIs or PLCs from data loss in case of a power failure. Therefore a special external signal will start the shutdown of the PC, HMI or PLC system. No matter how long it takes to shutdown, the capacitor UPS will supply the power for the system.

TECHNICAL DATA

MARKING

IECEX	
GAS EXPLOSION PROTECTION	Ex db eb IIC T6, T5, T4 Gb
DUST EXPLOSION PROTECTION	Ex tb IIC T80°C, T95°C Db

ATEX

GAS EXPLOSION PROTECTION	⊕ II 2 G Ex db eb IIC T6/5/4 Gb
DUST EXPLOSION PROTECTION	⊕ II 2 D Ex tb IIC T80°C, T95°C Db

INSTALLATION

ZONE 1, 2 OR ZONE 21, 22

CERTIFICATES

IECEX	IECEX PTB 07.0029
ATEX	PTB 06 ATEX 1077

AMBIENT CONDITIONS

AMBIENT TEMPERATURE	- 55 ... + 55°C
DEGREE OF PROTECTION	IP66

ELECTRICAL DATA

INPUT VOLTAGE DC	12V / 24V DC
INPUT VOLTAGE AC	340 - 550V AC; 115 - 230V AC
OUTPUT VOLTAGE	12V / 24V DC

MECHANICAL DATA

DIMENSIONS	STARTING FROM 290 x 290 x 230
WEIGHT	STARTING FROM 12KG

ENCLOSURE MATERIAL

FLAMEPROOF ENCLOSURE	ALUMINIUM (COPPER-FREE) OTHER MATERIAL ON DEMAND
CONNECTION CHAMBER	GLASS-FIBRE REINFORCED POLYESTER RESIN (GRP), DARK GREY, SIMILAR TO RAL 7024 GALVANIZED SHEET STEEL, POWDER COATED, LIGHT GREY, RAL 7035 STAINLESS STEEL WITHOUT POWDER COATING (OPTION)

STANDARD UPS



MAIN FEATURES

- Power range AC up to 500 VA
- Power range DC up to 300 W
- Offline UPS (for AC systems)
- SOC and SOH battery monitoring
- Temperature-guided battery charging
- Special Zone 2 adapted version available
- Compact version with Lithium-Ion technology and minimized footprint available

TYPICAL APPLICATIONS

- HMI, Safe shutdown of PC or PLC
- Helideck Lighting
- Machinery and plants: Elevators, Cranes, Drilling
- Automation: CCTV, Wireless
- Telecommunication installations

BENEFITS

- Modular design using Ex d and Ex e technique
- Low footprint
- The lightweight and compact UPS enables a safe shutdown in combination with HMI or PC.
- 1:1 redundancy possible

TECHNICAL DATA

MARKING

ATEX	
EXPLOSION PROTECTION INSTALLATION	⊕ II 2 G Ex db eb IIC T4 Gb ZONE 1, 2

CERTIFICATES

ATEX	PTB 06 ATEX 1077
------	------------------

AMBIENT CONDITIONS

AMBIENT TEMPERATURE	- 20 ... + 50°C
DEGREE OF PROTECTION	IP66 (BATTERY BOX IP23)

ELECTRICAL DATA

INPUT	120V / 230V AC, 100 ... 240V AC / 24V DC
OUTPUT	120V / 230V AC 24V DC
BATTERY	VRLA

MECHANICAL DATA

DIMENSIONS	STARTING FROM 290 x 290 x 230
WEIGHT	STARTING FROM 200KG

ENCLOSURE MATERIAL

Ex d	ALUMINIUM (COPPER-FREE) OR STAINLESS STEEL
Ex e	SHEET STEEL OR STAINLESS STEEL

COMPACT UPS



MAIN FEATURES

- Customized design
- Power range AC UPS up to 3.000 VA / DC UPS up to 2.000 W
- Both offline and online
- Temperature-guided battery charging
- Available as non redundant, partly and fully redundant systems
- Available in monoblock or modular design

TYPICAL APPLICATIONS

- NavAids
- Aircraft warning light; Lighting: helideck, emergency, parking; Offshore / Onshore: pumps, valves

BENEFITS

The maintenance-free UPS is simple to install and can provide a backup time up to 2 hours, depending on the load and the battery capacity. The UPS is available for varied requirements.

TECHNICAL DATA

MARKING

IECEX	
GAS EXPLOSION PROTECTION	Ex db eb IIC T6, T5, T4 Gb
DUST EXPLOSION PROTECTION	Ex tb IIC T80°C, T95°C Db

ATEX	
EXPLOSION PROTECTION	⊕ II 2 G Ex db eb IIB T4/T5
Gb	
INSTALLATION	ZONE 1, 2

CERTIFICATES

IECEX	IECEX KEM 07.0051X
ATEX	KEMA 01 ATEX 2145 X

AMBIENT CONDITIONS

AMBIENT TEMPERATURE	- 20 ... + 50°C
DEGREE OF PROTECTION	IP66

BATTERY

VRLA OR NI-CD

ELECTRICAL DATA AC AND DC UPS

INPUT	120V AC, 230V AC, 400V AC
OUTPUT	24V DC, 48V DC, 110V DC

MECHANICAL DATA

DIMENSIONS	STARTING FROM 290 x 290 x 230
WEIGHT	STARTING FROM 200KG

ENCLOSURE MATERIAL

Ex d	ALUMINIUM (COPPER-FREE) OR STAINLESS STEEL
Ex e	SHEET STEEL OR STAINLESS STEEL

POWER UPS



MAIN FEATURES

- Power range AC up to 7.000 VA
- Temperature-guided battery charging
- Available as non redundant, partly and fully redundant systems
- Available in monoblock or modular design

TYPICAL APPLICATIONS

- Offshore / Onshore: pumps, valves
- Energy distribution downstream
- Safety ensured power supply
- Lighting, NavAid

BENEFITS

The UPS uses either the Thyristor or IGBT technology. Additionally the UPS has both, an AC and a DC output. An overvoltage limiter (OVL) is optionally available.

TECHNICAL DATA

MARKING

IECEX	Ex db eb IIC T6, T5, T4 Gb
GAS EXPLOSION PROTECTION	Ex tb IIC T80°C, T95°C Db
DUST EXPLOSION PROTECTION	
ATEX	
EXPLOSION PROTECTION	⊕ II 2 G Ex db eb IIB T4 Gb
INSTALLATION	ZONE 1, 2

CERTIFICATES

IECEX	IECEX KEM 07.0051X
ATEX	KEMA 01 ATEX 2145 X

AMBIENT CONDITIONS

AMBIENT TEMPERATURE	- 20 ... + 55°C
DEGREE OF PROTECTION	IP66

ELECTRICAL DATA

INPUT VOLTAGE	400V AC, 3-PH.
OUTPUT VOLTAGE	24V DC

ENCLOSURE MATERIAL

Ex d	ALUMINIUM (COPPER-FREE) OR STAINLESS STEEL
Ex e	SHEET STEEL OR STAINLESS STEEL

OFF-GRID UPS



MAIN FEATURES

- Power range up to 4.000 W
- AC or DC output
- Temperature-guided battery charging

TYPICAL APPLICATIONS

- Offshore: NavAid, Wireless, CCTV, Automation
- Pipeline: CCTV, Valve Control, Power Supply, Automation
- Autonomous lighting systems

BENEFITS

The Off-Grid UPS is equipped with a high performance solar module which provides a high level of efficiency. We ensure a 5 year product guarantee and a 20 year performance guarantee (80% of the output).

Furthermore the system is available in extended versions with integrated solutions like HMI, camera systems and lighting. Complete solution including frame work according to customer's requirements.

TECHNICAL DATA

MARKING

ATEX	
GAS EXPLOSION PROTECTION	⊕ II 2 G Ex db eb IIB T4 Gb
INSTALLATION	ZONE 1, 2

CERTIFICATES

ATEX	KEMA 04 ATEX 2145X
------	--------------------

AMBIENT CONDITIONS

AMBIENT TEMPERATURE	- 50 ... +55°C
DEGREE OF PROTECTION	IP66

ELECTRICAL DATA AC AND DC UPS

OUTPUT VOLTAGE	230V AC
	24C DC

ENCLOSURE MATERIAL

SEAWATER RESISTANT ALUMINUM ALLOY ACCC. TO EN 13195 (COPPER-FREE) AND SS 316L

COMPLEMENTARY EQUIPMENT

DISTRIBUTION BOARDS AC/DC



- Distribution boards AC or DC
- available in GRP housing, aluminium (copper-free), stainless steel or sheet steel in Ex d or Ex e technology
- low maintenance
- easy operation with certifications for worldwide use

BATTERY BREAKERS



- Reliable switching of currents up to 1200 A according to ATEX / IECEx directive for Zone 1 and 2
- available in Ex d and Ex e technology
- Hassle free commissioning and maintenance
- Manual disconnection of circuits possible

BATTERY BOXES



- The battery container type BC is designed especially to operate under harsh environmental conditions and outdoor use for onshore and offshore environment
- ATEX certification is available

DESIGN CRITERIA

R. STAHL is the perfect partner for UPS solutions. Our expertise is the base for every UPS solution. Different parameters have direct influence on the design of a UPS solution.

Design parameters and their influence

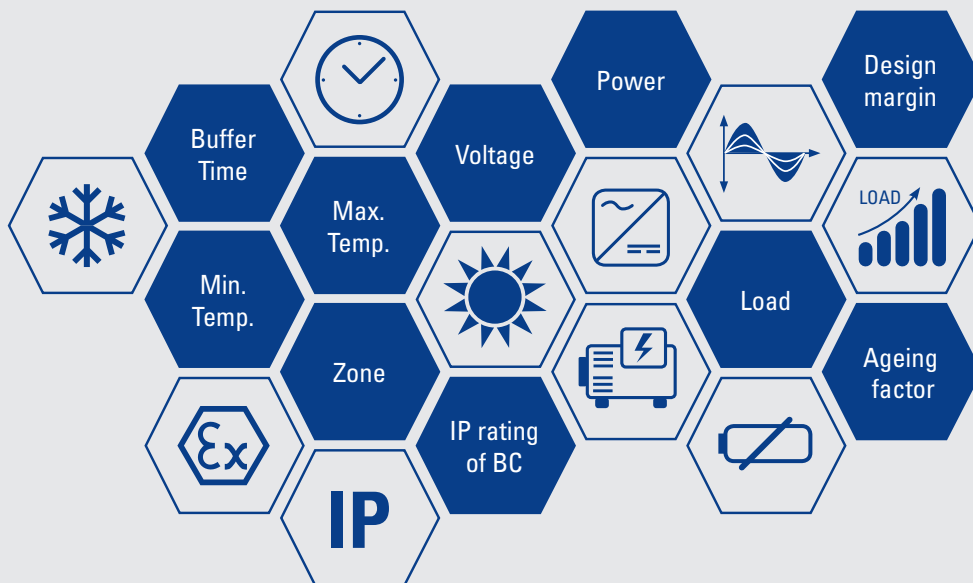

BUFFER TIME:	The longer the buffer time the larger the battery and the charger
VOLTAGE:	System design depends on voltage
POWER:	Power factor has influence on charger sizing and system design
LOAD:	The higher the load the larger the charger
EX RATING:	Special Zone 2 products available
AGEING FACTOR:	The higher the ageing factor the larger the battery and charger
DESIGN FACTOR:	The higher the design factor the larger the battery and charger
IP RATING:	High IP requirements require special battery containers
MIN. TEMP.:	The lower the temperature (below +20 °C) the larger the battery
MAX. TEMP.:	The higher the temperature (above +20 °C) the shorter the lifetime of the battery and the longer the recharge time

CHECKLIST

The correct information is important for an effective work. This checklist should help to prepare necessary information for R. STAHL. With the information we are able to design a proper system for our customer. If the checklist is not complete R. STAHL can create budgetary quotes based on the existing information and on the expertise of R. STAHL.

UPS checklist

GENERAL DATA

Project

Quantity

EXPLOSION PROTECTION

Zone	UPS <input type="checkbox"/> Zone 1 <input type="checkbox"/> Zone 2 <input type="checkbox"/> Safe area		Battery box <input type="checkbox"/> Zone 1 <input type="checkbox"/> Zone 2 <input type="checkbox"/> Safe area	
Gas group	<input type="checkbox"/> IIA	<input type="checkbox"/> IIB	<input type="checkbox"/> IIB+H2	<input type="checkbox"/> IIC
Temperature class	<input type="checkbox"/> T3	<input type="checkbox"/> T4	<input type="checkbox"/> T5	<input type="checkbox"/> T6
Certification	<input type="checkbox"/> ATEX	<input type="checkbox"/> IECEX	<input type="checkbox"/> Others	

TECHNICAL DATA

Ambient conditions	<input type="checkbox"/> Continental conditions		<input type="checkbox"/> Marine conditions	
Buffer time d h min			
Max. recharge time d h min			
Footprint	Available width cm Available high cm Available depth cm			
Ambient temperature	UPS Min. °C Max. °C Humidity%		Battery box Min. °C Max. °C Humidity%	
IP rating	UPS <input type="checkbox"/> IP65 (standard) <input type="checkbox"/> IP.....		Battery box <input type="checkbox"/> IP23 (standard) <input type="checkbox"/> IP.....	
Input voltage¹	Alternating current (AC) Voltage V Frequency Hz	<input type="checkbox"/> 1 phase+N <input type="checkbox"/> 3 phase+N <input type="checkbox"/> 3 phase	Direct current (DC) Voltage V	
Output voltage¹	Alternating current (AC) Voltage V Frequency Hz	<input type="checkbox"/> 1 phase+N <input type="checkbox"/> 3 phase+N <input type="checkbox"/> 3 phase	Direct current (DC) Nominal voltage V Tolerance ± % (standard 15 %)	
Load¹	Alternating current (AC) VA Power factor cos φ		Direct current (DC) W	
Redundancy	<input type="checkbox"/> Not required		<input type="checkbox"/> Required Charger % redundancy Battery % redundancy	
AC UPS specific points	Operation mode <input type="checkbox"/> Offline (VFD) <input type="checkbox"/> Online (VFI)		Bypass <input type="checkbox"/> Not required <input type="checkbox"/> Manual <input type="checkbox"/> Automatic	

¹ Either AC or DC to be selected

THE RESULT: A COMPLETE SYSTEM

The main focus is given with the core system of a UPS. Furthermore, all belonging components which are relevant for the complete system may come from the same technical design and matching perfectly into the plant requirements as well as into the system requirements.

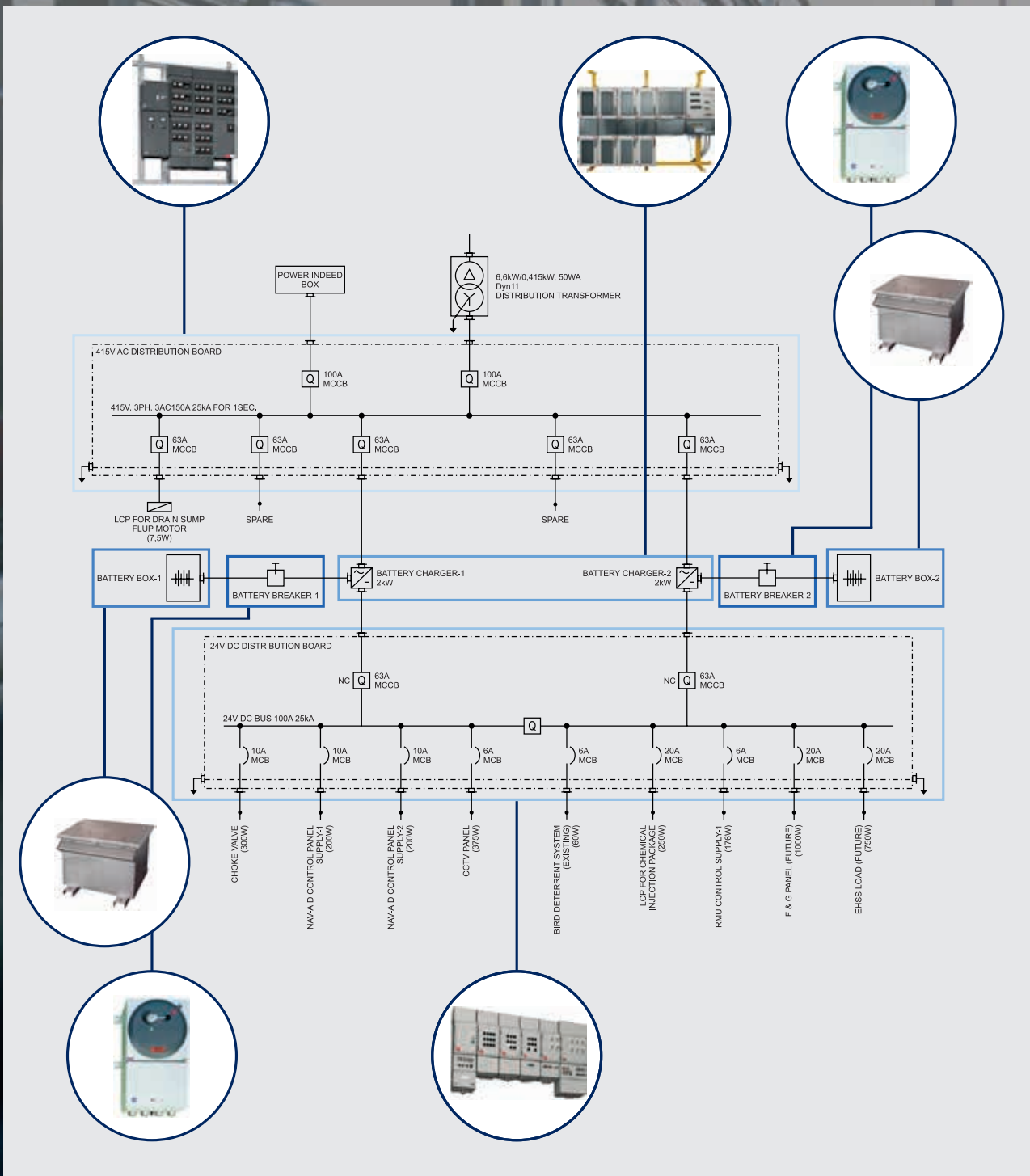

WITHOUT BORDERS FOR EVERY APPLICATION

R. STAHL is at home all over the world and with its more than 74 subsidiaries and agents always close to you. With great commitment, competent teams meet the customers' requirements and ensure that they comply with national standards and the specific environmental conditions. Irrespective of climatic conditions, whether the environment is corrosively or harsh, the system solutions of R. STAHL always guarantee a high level of safety and ensure the explosion protection. Our solutions can be used worldwide in pharmaceutical plants, in harsh offshore operations or in places with extreme high or low ambient temperatures. All standard components come with a high level of ingress protection and are suitable for all typical applications. For products, which will be used in maritime environment different types of enclosures are available, e.g. seawater-resistant aluminum enclosures with a copper content of less than 0.5 %, high-quality stainless steel enclosures or salt-water resistant polyester enclosures. The accrue-ment of condensate inside the enclosures in case of high temperature differences can effectively be avoided by using heating elements or breathers. The solutions of R. STAHL have already been successfully tested and installed in applications and projects around the world.

International certification

- IECEx, CENELEC and NEC

Ambient temperature range

- -20°C ... +40°C
- -50°C ... +55°C
- Others on request

Sea water resistant

- Stainless steel, AISI 316L
- GRP
- Copper-free aluminium

Safe and reliable technology

- Quality assurance is implemented in all manufacturing steps and is one of our major management principles

Proven and robust products

- 80 years of experience in development and manufacturing

Installation techniques

- Direct entry with cable glands
- Direct entry with conduits
- Indirect cable entry with connection chamber

Type of protection (IP-rating)

- IP65 and IP66

Worldwide organisation

- Over 70 subsidiaries for your support with explosion protection

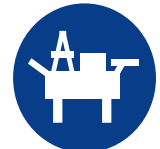



R. STAHL
Am Bahnhof 30
74638 Waldenburg, Germany
T +49 7942 943-0
F +49 7942 943-4333
Integrated.solutions@stahl.de
r-stahl.com

